

User Guide

CATIA V5> 3D PDF

Product Category	CADPublish
Product Group	CATIA V5>3D PDF
Product Release Version	28.0

Document Type	User Guide
Document Status	Released
Document Revision	1.0
Document Author	Bruce Pittman
Document Issued	08/07/2025

📍 THEOREM HOUSE
MARSTON PARK
BONEHILL RD
TAMWORTH
B78 3HU
UNITED KINGDOM

☎ +44(0)1827 305 350

📍 THEOREM SOLUTIONS INC.
100 WEST BIG BEAVER
TROY
MICHIGAN
48084
USA

☎ +(513) 576 1100

Contents

Overview of TRANSLATE.....	4
<i>About Theorem</i>	<i>4</i>
<i>Theorem's Product Suite</i>	<i>5</i>
CADTranslate	5
CADPublish.....	5
TheoremXR	5
Overview of CADPublish.....	6
<i>What is a 3D PDF?.....</i>	<i>6</i>
<i>What is CADPublish?</i>	<i>7</i>
<i>What does CADPublish provide?</i>	<i>7</i>
<i>CADPublish supplied templates</i>	<i>8</i>
CATIA V5 to 3D PDF – CADPublish	9
<i>The CATIA V5 to 3D PDF Uni-directional Translator.....</i>	<i>9</i>
<i>Primary Product Features.....</i>	<i>9</i>
<i>Primary Product benefits?</i>	<i>9</i>
Getting Started.....	10
<i>Documentation & Installation Media</i>	<i>10</i>
<i>Installation</i>	<i>11</i>
<i>License Configuration</i>	<i>11</i>
<i>Using the Product.....</i>	<i>11</i>
Translating Interactively from within CATIA V5	12
<i>Launching CATIA V5 with Theorem plug-ins.....</i>	<i>12</i>
<i>Default Translation from CATIA V5.....</i>	<i>13</i>
<i>Accessing the Configuration Manager in CATIA V5</i>	<i>15</i>
Translating in the Unified Interface	19
<i>Default Translation in the Unified Interface</i>	<i>19</i>
<i>Accessing the Configuration Manager in the Unified Interface</i>	<i>21</i>
Configuration Manager	24
Advanced Arguments.....	36
<i>CATIA V5 Advanced Arguments.....</i>	<i>36</i>
<i>3DPDF Advanced Arguments.....</i>	<i>37</i>
Translating on the Command Line	46
<i>Default Translation on the Command Line</i>	<i>46</i>
<i>Translating with Options on the Command Line.....</i>	<i>47</i>

Templates.....	48
<i>Publishing to specified Templates – via the Configuration Manager.....</i>	<i>48</i>
<i>Publishing to specified Templates – via the Command Line.....</i>	<i>50</i>
<i>Publishing without a Template – via the Configuration Manager.....</i>	<i>52</i>
<i>Publishing without a Template – via the Command Line.....</i>	<i>53</i>
Appendix A – Security Changes to Adobe Reader PDF Documents.....	54

Overview of TRANSLATE

About Theorem

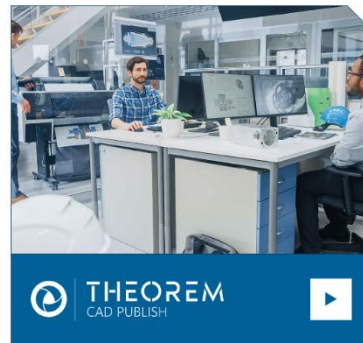

Theorem Solutions is a world leader in the field of Engineering Data Services and Solutions. This leadership position stems from the quality of our technology and the people in the company. Quality comes not only from the skills and commitment of our staff, but also from the vigorous industrial use of our technology & services by world leading customers.

We are proud that the vast majority of the world's leading Automotive, Aerospace, Defense, Power Generation and Transportation companies and their Supply chains use our products and services daily. Working closely with our customers, to both fully understand their requirements and feed their input into our development processes has significantly contributed to our technology and industry knowledge.

Theorem Solutions is an independent UK headquartered company incorporated in 1990, with sales and support offices in the UK and USA. Theorem has strong relationships with the major CAD and PLM vendors, including; Autodesk, Dassault Systemes, ICEM Technologies (a Dassault company), PTC, SolidWorks, Spatial Technology and Siemens PLM Software. These relationships enable us to deliver best in class services and solutions to engineering companies worldwide.

Theorem's Product Suite

Theorem have 3 main Product brands. These are:



CADTranslate

CAD Data Exchange: Seamless and robust data translation between CAD and Visualization formats.

See our [website](#) for more detail.



CADPublish

Interactive Documentation: 3D PDF Publisher and Composer. Making CAD data accessible to non-CAD users.

See our [website](#) for more detail.



TheoremXR

Visualization for [Augmented \(AR\)](#), [Mixed \(MR\)](#) and [Virtual \(VR\)](#) Reality applications

Extended Reality – XR: Augmented, Mixed and Virtual Reality for the Engineering Metaverse.

See our [website](#) for more detail.

Overview of CADPublish

What is a 3D PDF?

In its simplest form a 3D PDF is a standard Adobe PDF document that contains interactive 3D content.

A PDF is a document format that can contain:

- 2D Graphics.
- 3D Graphics (3D CAD model.)
- Attached files to form a Technical Data Package.
- The ability to interrogate and interact with the document.
- The ability to universally review CAD with a free viewer.
- Compressed data for optimum file size sharing.
- Support for Model Based Definition (MBD).
- The addition of 3D content to a PDF allows your company:
 - To produce documents to fully describe the product.
 - To achieve effective communication regarding product information.
 - To automate specific business processes.
 - To improve understanding and eliminate ambiguity in relation to product data.
 - To create and extend customised, dynamic documents.
 - To create rich documents with 3D content which can be consumed anywhere.
 - To create interactive and engaging documents such as brochures.

It's already used for documents which commonly relate to products e.g.; Request for Quotation, Engineering Change Requests, Bill of Material reports, Inspection Documents, Works instructions, Service manuals, Sales literature, etc.

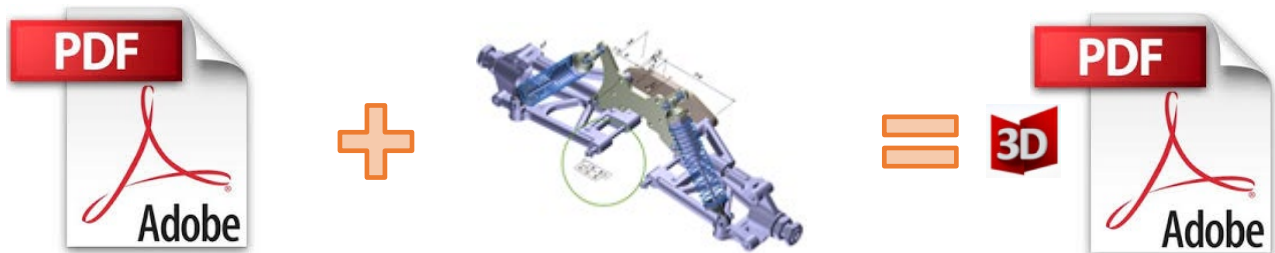

Review our website [here](#) for a short video explaining 3D PDF or review our [Frequently asked questions](#) for more information

What is CADPublish?

Theorem's CADPublish brand offers a 3D PDF publishing solution for organisations who design with 3DEXperience, CATIA V5, Creo, NX or who want to extend the use of their JT data to create interactive 3D documentation (3D PDF's.)

The use of 3D PDF means that anybody can now consume, view and mark up 3D data with Adobe's ubiquitous Reader, eliminating the need to install specialist viewing software or to be trained to use a special tool.

Designed for organizations of all sizes, CADPublish solutions are based on the original Adobe® and vendor specific technology, therefore are fully compatible with Acrobat and native CAD systems enabling users to take the intelligence contained within a 3D model directly into the world of PDF.

Theorem's CADPublish suite of products is powered by native Adobe® technology 3D PDF publishing toolkit, which is also used in Adobe Acrobat® and Adobe Reader®.

For more information regarding our CADPublish brand, please contact sales@theorem.com

What does CADPublish provide?

Theorem Solutions' CADPublish suite of applications includes:

- **CADPublish Create**
 - 3D PDF Publishing from within CAD Applications:
 - 3DEXperience / CATIA V5 / Creo / NX

- **CADPublish Enhance**
 - Batch Publishing for:
 - 3DEXperience / CATIA V5 / Creo / NX / JT

CADPublish supplied templates

Both the CADPublish Create and CADPublish Enhance brands allow the user to create custom configurations. This enables the user to select a specific template in which to translate their source data in to, including the example templates below.

Example templates are provided in the following location:

<installation_directory>\data\publish_3dpdf\templates

The following examples are available:

- BOM – Illustrates how to output an Assembly Bill of Materials.
- Assembly_Viewer – Illustrates JavaScript additions to a template replicating a CAD viewer.
- Technical_Data_Package – Illustrates adding attachments to a template and the free movement of geometry, along with the JavaScript additions.
- PMI_Analysis – Illustrates how to output a PMI list and filter either by type or by view.

These templates are supplied as examples only and can be used by customers as a guide in creating their own template documents.

Theorem offer a wide range of services to assist customers with their document creation needs. If you would like more information regarding our template design services, please contact sales@theorem.com quoting “3D PDF Template Design”.

The remainder of this document will focus on CADPublish for 3DExperience. For further information on other Theorem CADPublish Products please contact sales@theorem.com

CATIA V5 to 3D PDF – CADPublish

The CATIA V5 to 3D PDF Uni-directional Translator

The CATIA V5 to 3D PDF translator may be installed on a number of machines accessing a central network-floating license.

The CATIA V5 to 3D PDF translator is a Uni-directional direct database converter between the Dassault Systemes CATIA V5 modelling application and PDF file format.

It enables the user to convert all forms of 3D Mechanical Design Geometry and Assembly data, together with system defined attribute information and colour information, between these two systems. This product is designed for companies using CATIA V5 who have selected PDF to be their main method of visualisation and/or collaboration either internally or between OEMs and their customers or suppliers.

It is also a major method of visualisation and is used by companies using Adobe® based solutions to translate their CATIA V5 data into PDF format.

Primary Product Features

- Converts CATIA V5 data to 3D PDF documents.
- Converts assembly structures to PDF file format.
- Converts all types of geometry, wireframe, surfaces, trimmed surfaces (faces) and solid models.
- Converts attribute data including colour and layer information
- Integrated with the CATIA V5 installation.
- The conversion process can be run Interactively, in Batch Mode or using the Unified Interface.
- Uses the CATIA V5 API.

Primary Product benefits?

- Direct conversion from CATIA V5 to PDF reduces processing time, simplifies integration and ensures that the correct data is being published.
- Using the freely available Adobe Acrobat Reader application allows the user to visualise the 3D CAD data without incurring any additional costs.
- Provides improved communication and collaboration by visualising CATIA V5 data in a PDF.
- Allows 3D CAD data to be easily shared with non-CAD users.
- Allows for Comments and user-interactions to be saved to the PDF document for downstream updates allowing greater collaboration and communication between users.
- Allows for documents to be password protected improving the security of sensitive Information when sharing the data.
- Enables the data to be converted into a PDF template specified by the user.
- Allows for additional documents to be added as attachments.
- Reduce costs and risks associated to accessing the wrong version of data by integrating the publishing process into all related business processes.
- With over 30 years industrial use Theorem's product robustness and quality is well proven, reducing your business risk.

Getting Started

Documentation & Installation Media

The latest copy of the User Guide documentation can be found on our web site at:

<http://www.theorem.com/Documentation>

Each product has a specific link that provides user documentation in the form of PDF's and Tutorials.

The latest copy of Theorem software can be found via the link above and by searching for the specific product. See image below:

Documentation selector

Filter by product

CATIA V5 > 3D PDF

CATIA V5 > 3D PDF

Latest Release: Version V27.0

- [Product Release Notes](#)
- [User Guide](#)

Setup Tutorials

- [Software Installation](#)
- [Unified Interface Installation](#)
- [Flex Composite Host Generation](#)
- [License Server Configuration](#)
- [Define your license server](#)
- [Upload a custom template file](#)

Product Tutorials

- [Publish 3D On Demand – Process using the UI](#)
- [Publish 3D Interactive – Run CATIA V5 with Theorem integration](#)
- [Publish 3D Interactive – Create a 3D PDF from CATIA V5](#)
- [Publish 3D Interactive – Set a configuration within CATIA V5](#)
- [Publish 3D - Run via the Command Line](#)
- [Define a configuration using the configuration manager](#)
- [Define a configuration using the UI](#)

Legacy Product Release Notes:

- [Version 26.0](#)
- [Version 25.1](#)
- [Version 24.0](#)
- [Version 23.0](#)
- [Version 22.1](#)
- [Version 22.0](#)
- [Version 21.1](#)
- [Version 19.4](#)
- [Version 19.0](#)

Each product has a specific link to the Product Release Notes, which contains a link to the download location of the software.

Installation

The installation is run from the .msi file download provided. For full details of the installation process, visit www.theorem.com/documentation

License Configuration

To run any product, a valid license file and a Flex License Manager installation will be required. The Flex License Manager is run from the .msi file download provided. This can be accessed from the Product Release Notes. For full details of the installation process, visit www.theorem.com/documentation

Using the Product

To use the product, follow the documented steps found in this document or follow the online video tutorials which can be found from www.theorem.com/documentation

Translating Interactively from within CATIA V5

Launching CATIA V5 with Theorem plug-ins

The CATIA V5 to 3D PDF translator allows an active CATIA V5 Part or Assembly to be published directly into PDF from the CATIA V5 application.

In order to translate from within CATIA V5, the application must be started using a Theorem environment, so that the appropriate Theorem partner plug-ins are available.

CATIA V5 can be started from a desktop shortcut, if requested during installation.

Alternatively, it can be started via the script provided in the translator installation located in:

<installation_directory>\bin

The script name is:

catia5r<version>_start.cmd

Where <version> should be substituted for the version of CATIA V5 that you have installed – e.g. 32 for V5-6R2022, 33 for V5-6R2023, 34 for V5-6R2024 etc.

Default Translation from CATIA V5

Once CATIA V5 has been started, open the part or assembly that is going to be exported to PDF.

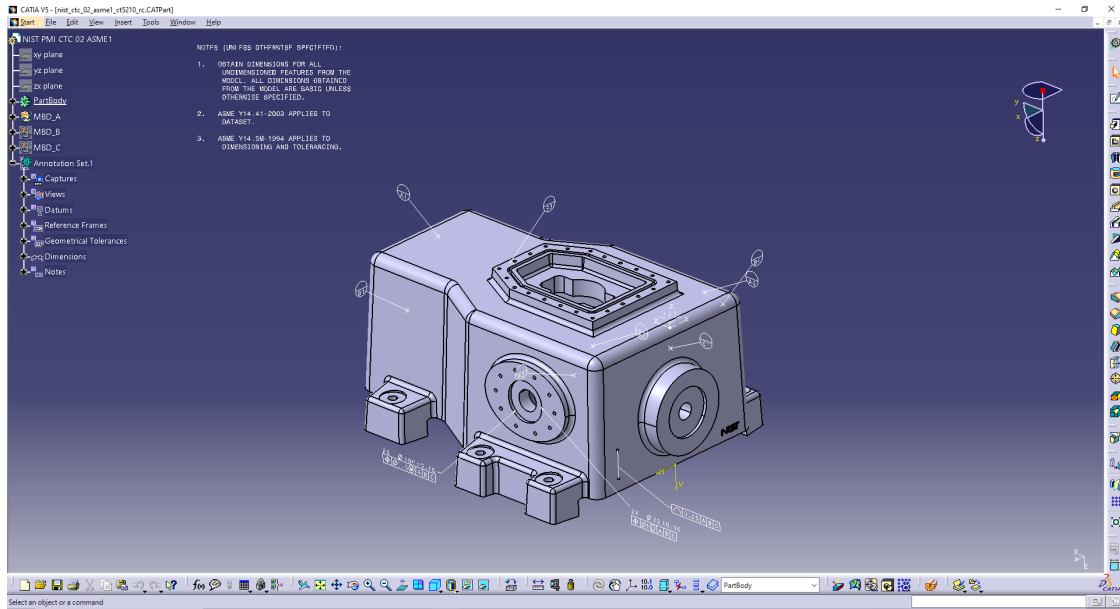

Select File, then Save As.

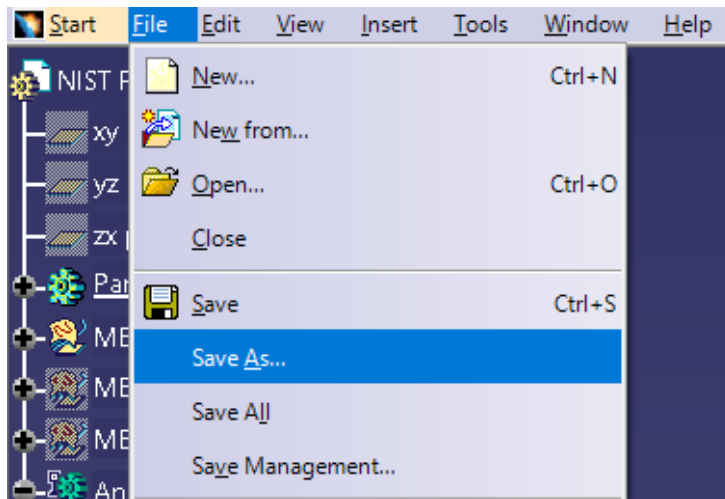

Select the required location for the file and in the Save As Type window select pdf (*.pdf)

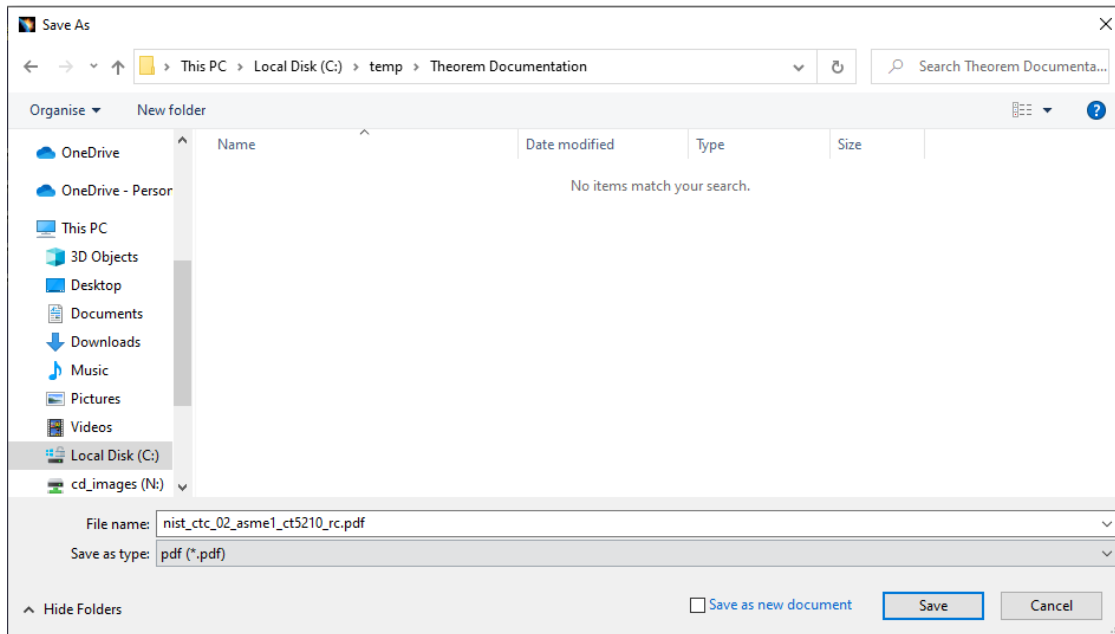

Click save to initiate the translation and create the PDF file in the location specified.

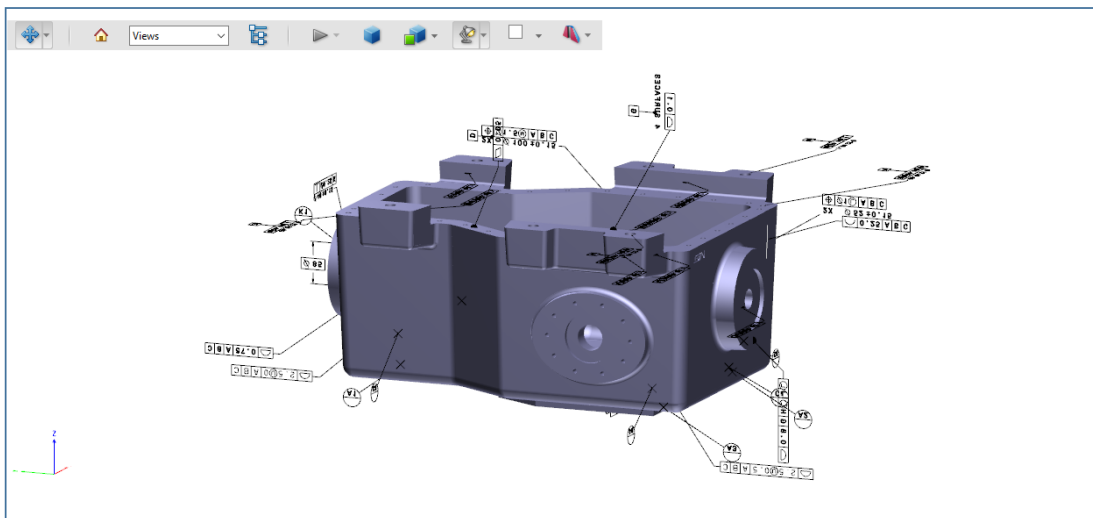

Accessing the Configuration Manager in CATIA V5

Users have the option to create Theorem configurations, selecting a predefined Theorem configuration, applying a document password, specifying the log file directory and specifying whether the PDF document is opened once created. These options are accessible from the Publish 3D PDF tab via Tools>Options>Infrastructure>Theorem.

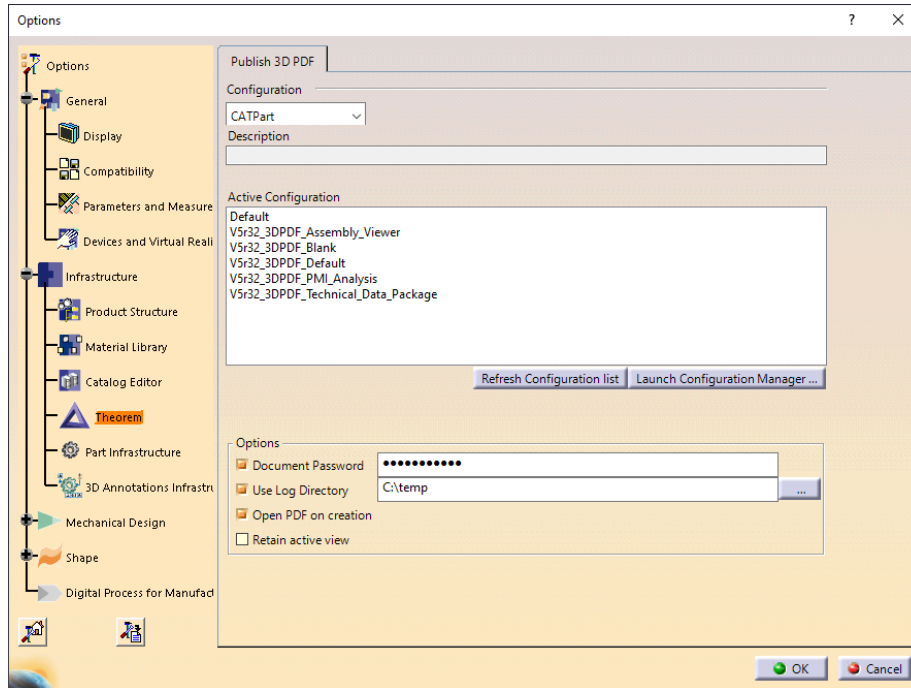

To create a new configuration, select the **'Launch Configuration Manager'** command.

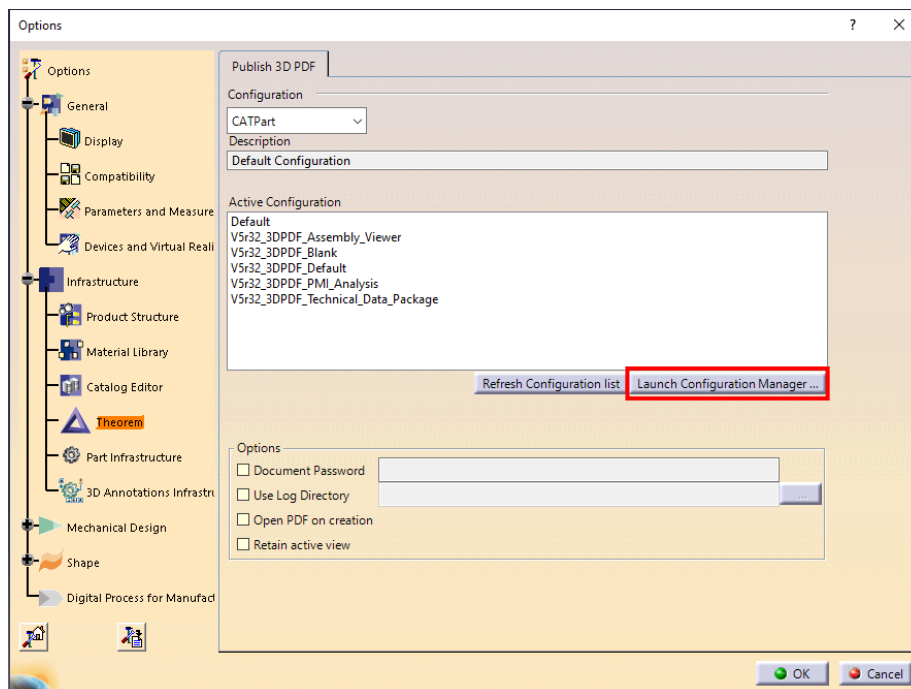

In the configuration manager window, select New, apply the relevant options, (see **Configuration Manager**), then rename the configuration as required. Click Exit to close the window.

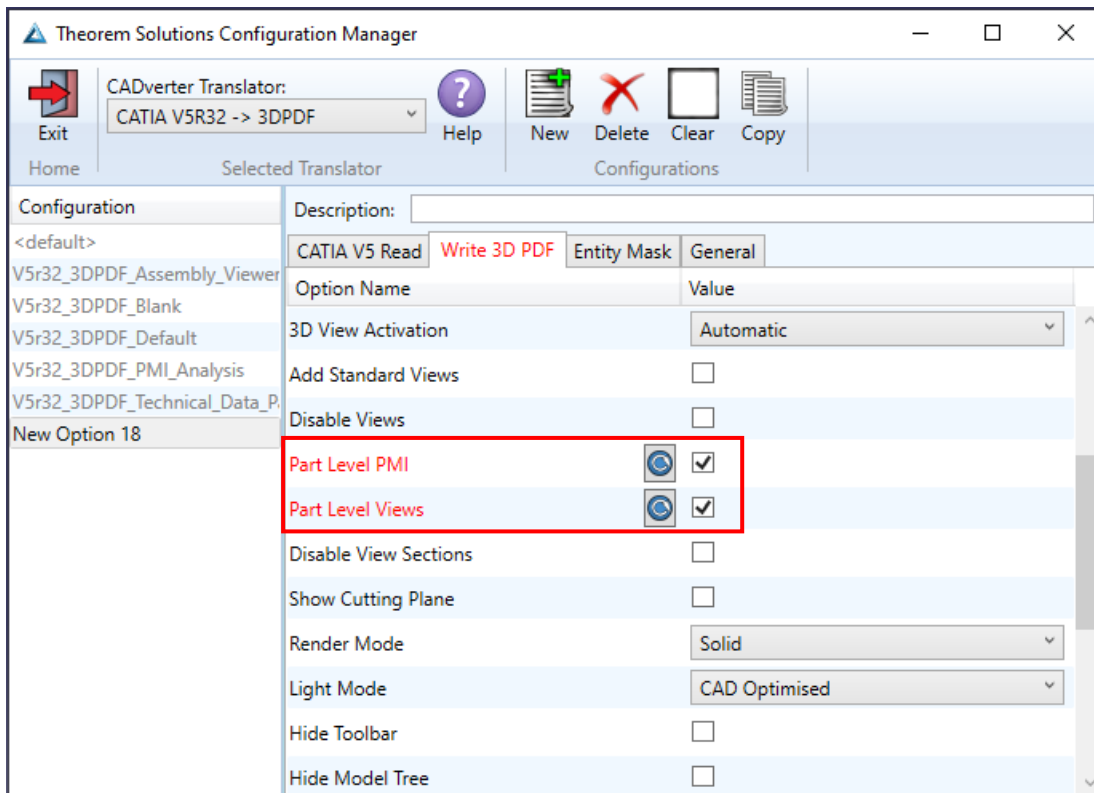
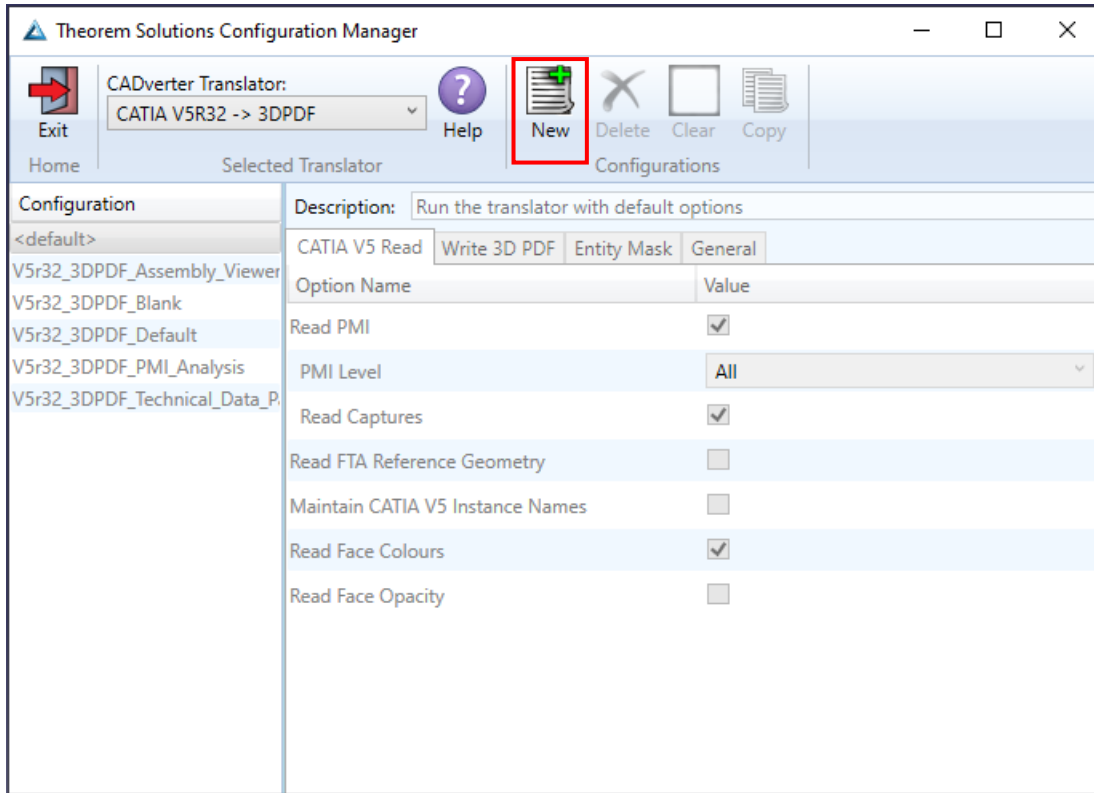

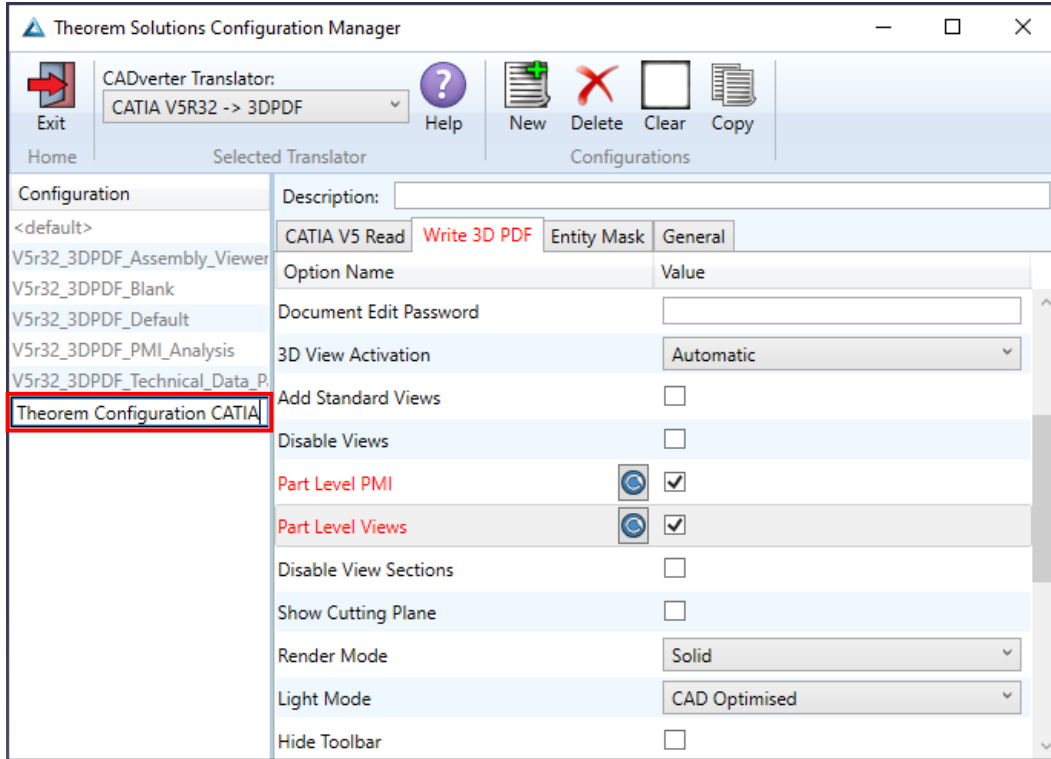

Any new configurations created will be displayed in the Active Configurations list once it has been refreshed. To do this select '**Refresh Configuration List**'. Any predefined configurations will also be displayed in the Active Configuration list.

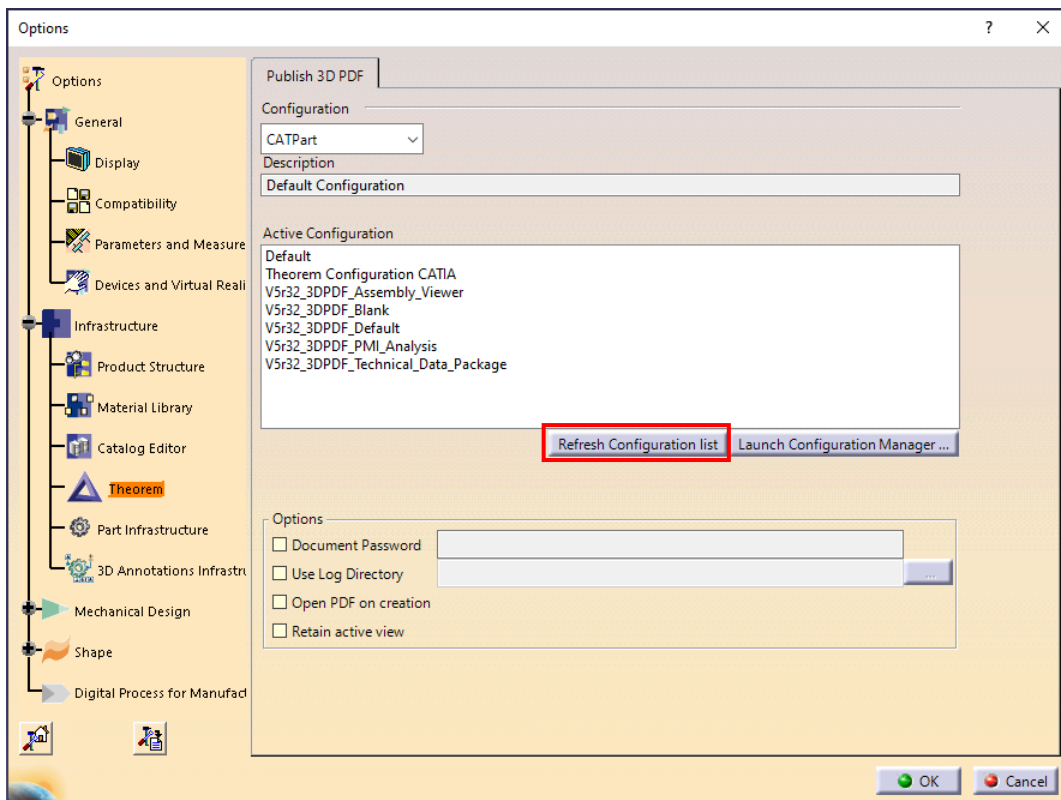

Select the required configuration to make it the active configuration. This will be highlighted in blue when selected.

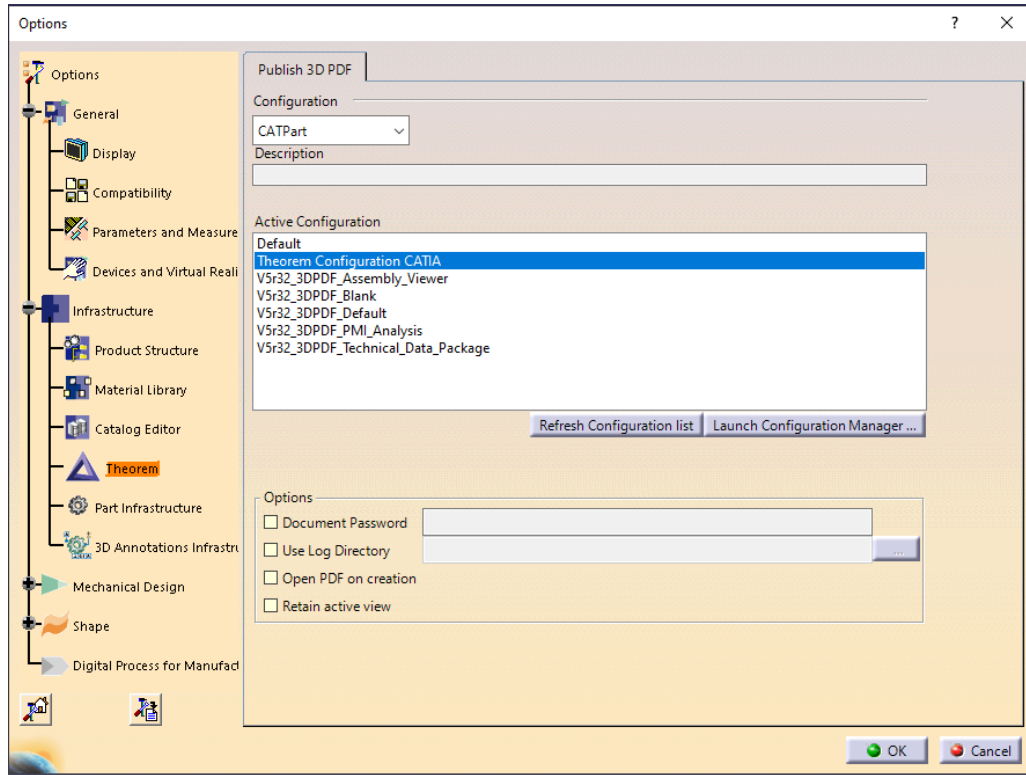

Translating in the Unified Interface

Default Translation in the Unified Interface

The Unified Interface can be started via a shortcut, if requested during installation.

Alternatively, it can be started via the script provided in the UI installation located in:

<UI_installation_directory>\bin

The script name is:

Unified_Interface.cmd

The following interface will be launched:

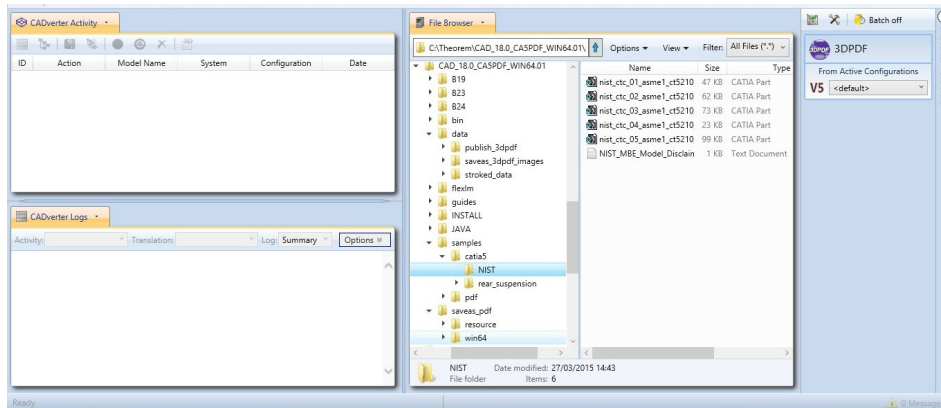

The default layout is split into 4 primary areas, which can be altered as per the user's preference:

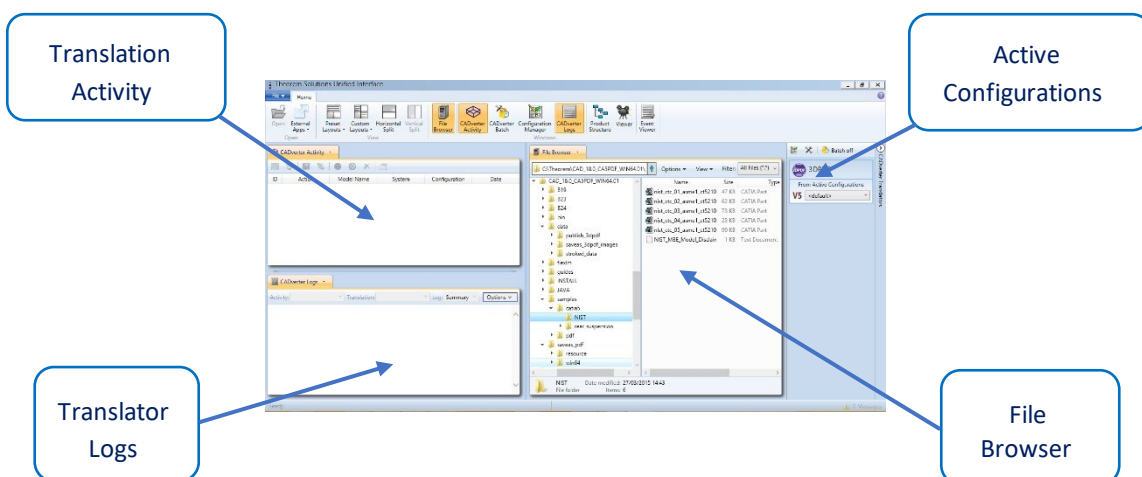

The simplest way to translate a CATIA V5 file to a 3D PDF is to drag the file from the file Browser tab on to the 3D PDF Active Configuration. This will create a PDF file based upon the default template.

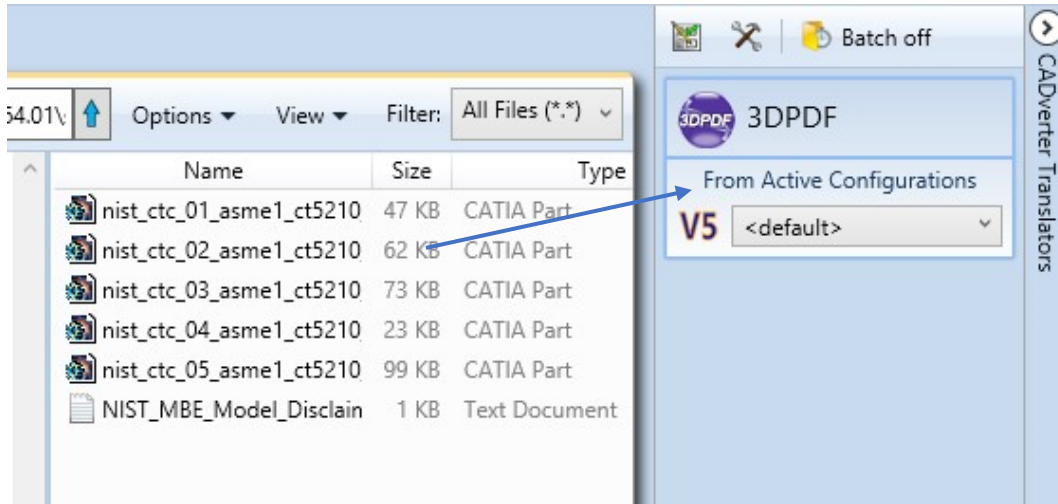

On completion, the Unified Interface will display the activity information and details from the log file created during the translation, in the Translation Activity and Translator Logs tabs respectively.

The generated output data can be located by selecting the translation from the Translator Activity tab and opening the output folder.

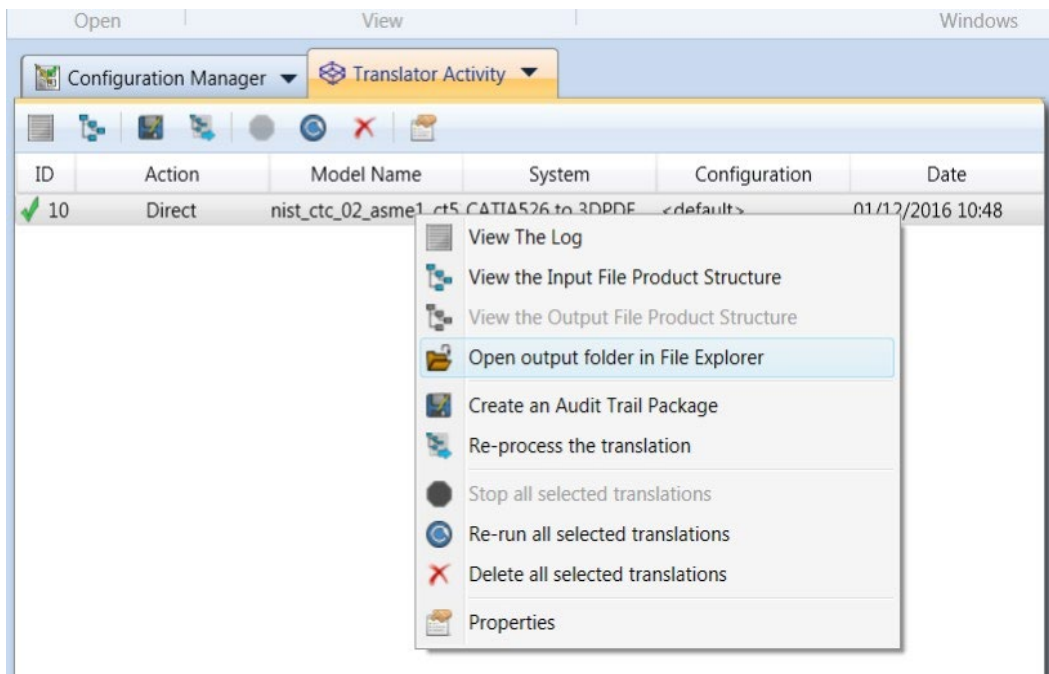

Accessing the Configuration Manager in the Unified Interface

To access the configuration manager in the UI, ensure that the Configuration Manager option has been toggled on in the ribbon at the top. The configuration manager option is visible under the Home tab.

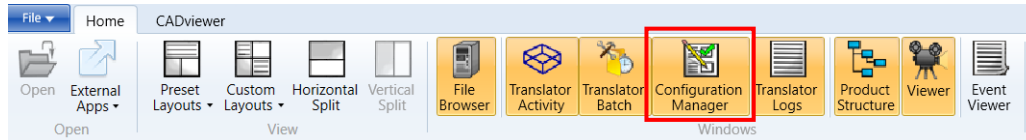

Once toggled on a Configuration Manager tab should be displayed as per the image below.

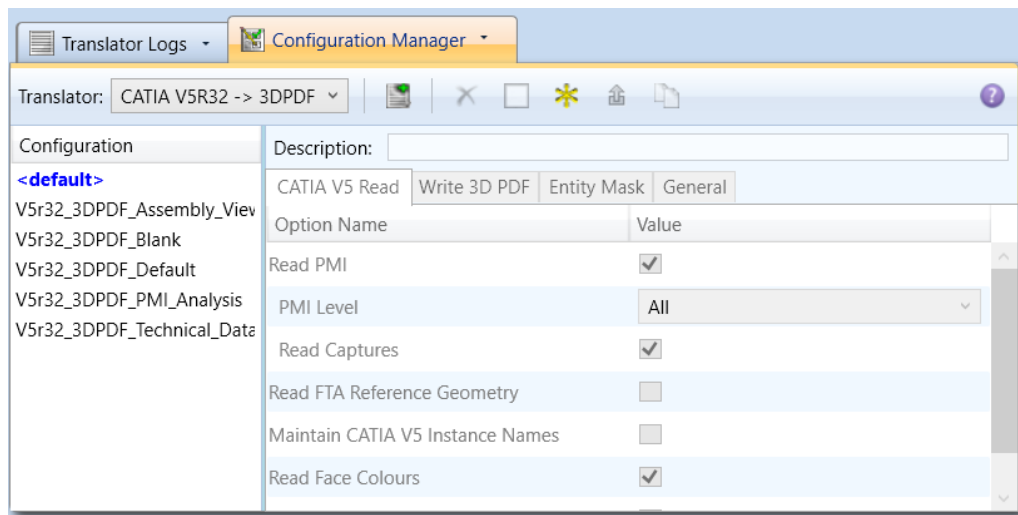

New Theorem configurations can then be created based upon all available options within the CATIA V5 to 3D PDF translator. To create a new configuration, select the **Add a New Configuration** icon in the configuration manager tab.

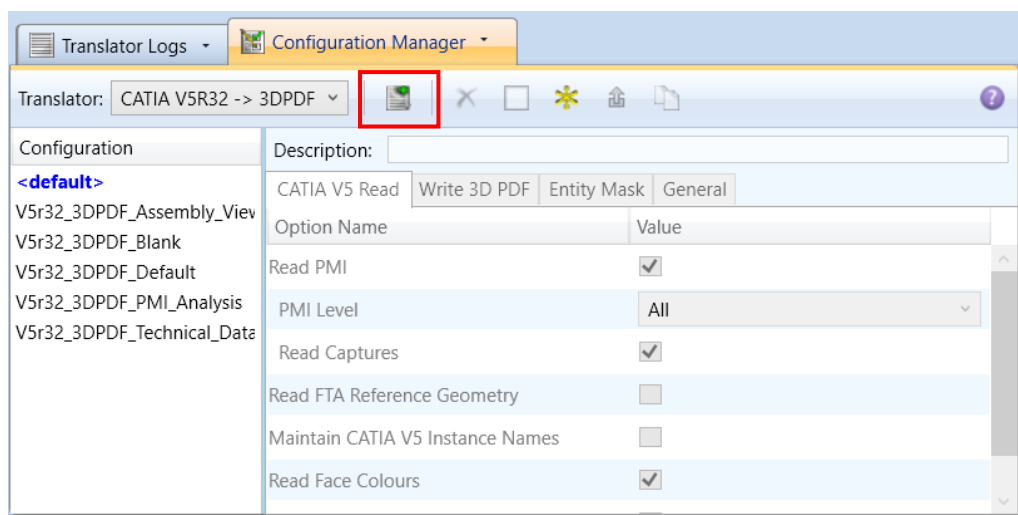

Apply the relevant options, (see **Configuration Manager**), then rename the configuration as required.

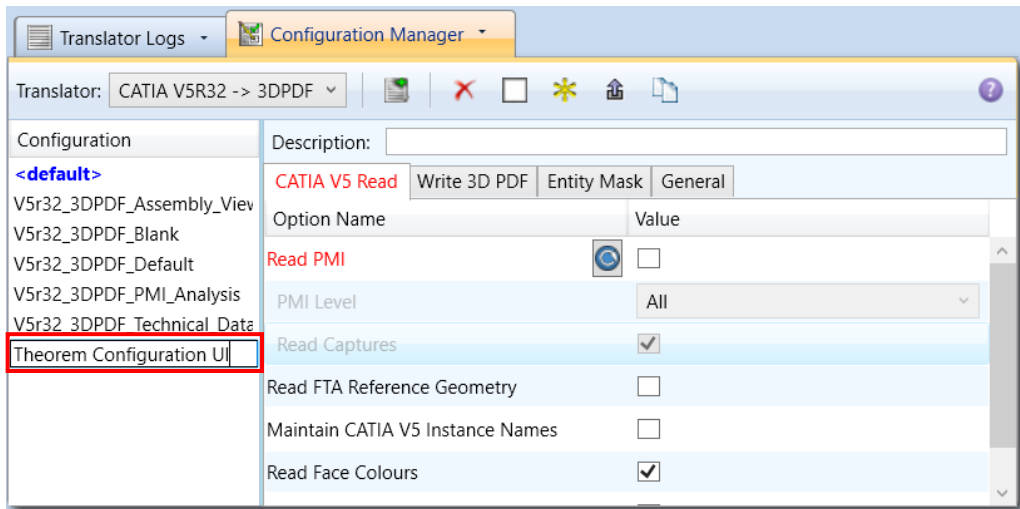
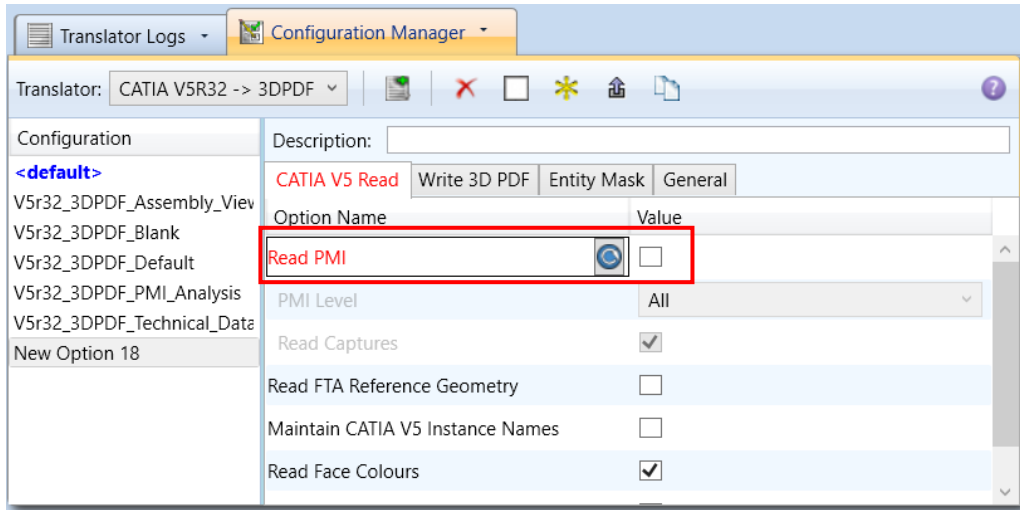

To make the new configuration created, the active configuration, select it and click on the **'Make the selected configuration the active configuration'** icon. The configuration name will then be highlighted in blue.

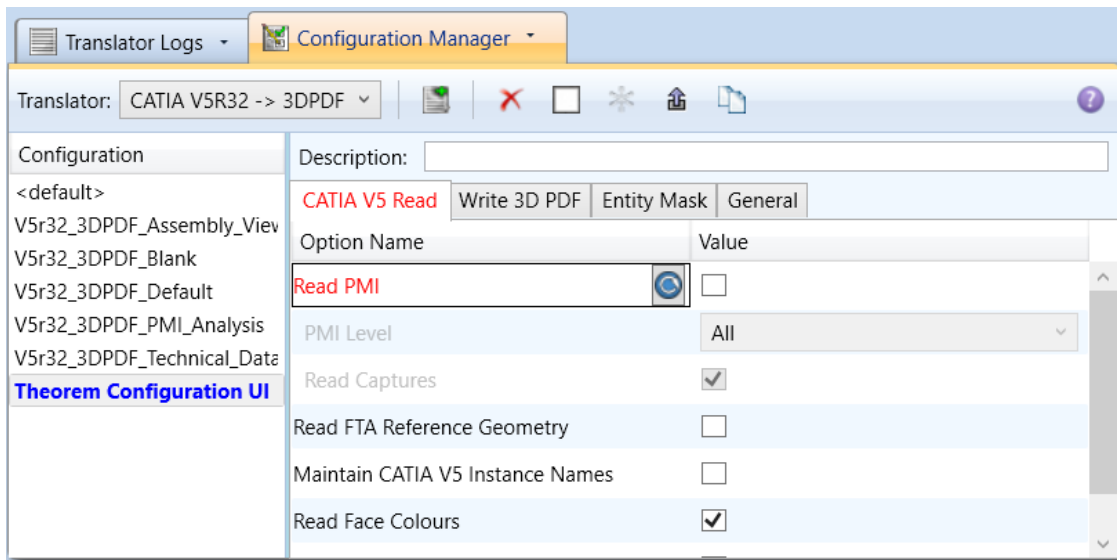
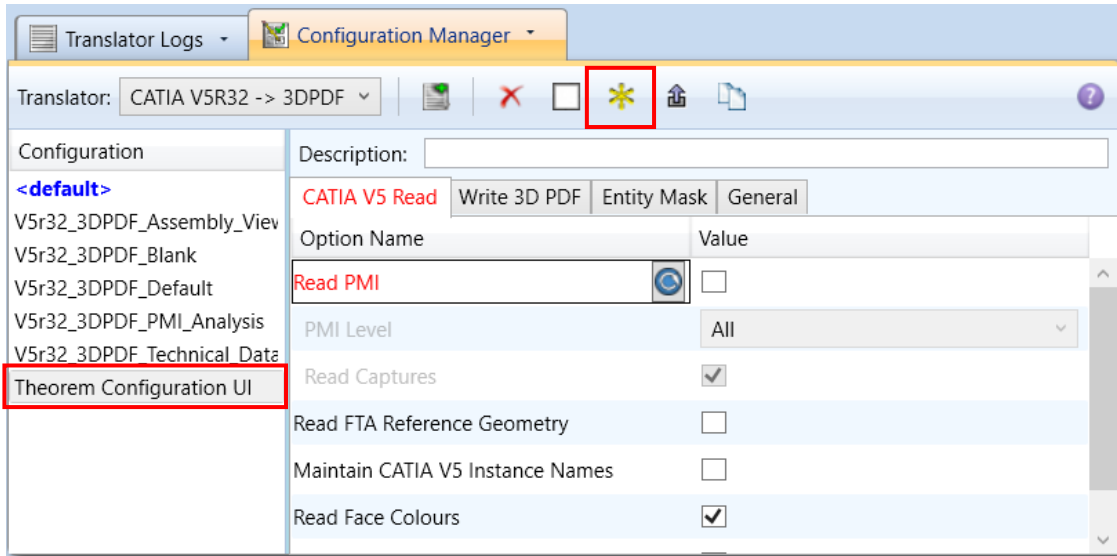

Configuration Manager

CADPublish allows the information that is read from the source system and written to the target system to be tailored via a set of user specified options. Commonly used options are supported via the Configuration Manager, with Advanced Arguments being described within this document for use in the Configuration Manager or via the Command Line invocation.

Within the Configuration Manager, the options that are available to use are grouped into the following 4 areas when translating data from CATIA V5 to 3DPDF.

- CATIA V5 Read – Those options that affect how data is read from CATIA V5
- Write 3D PDF – Those options that affect how the data is written to 3D PDF
- Entity Masking – Those arguments that allow specific read entities to be masked
- General – Those options that are common to ALL Publishing activities regardless of source data. Advanced arguments are added in this tab.

CATIA V5 Read

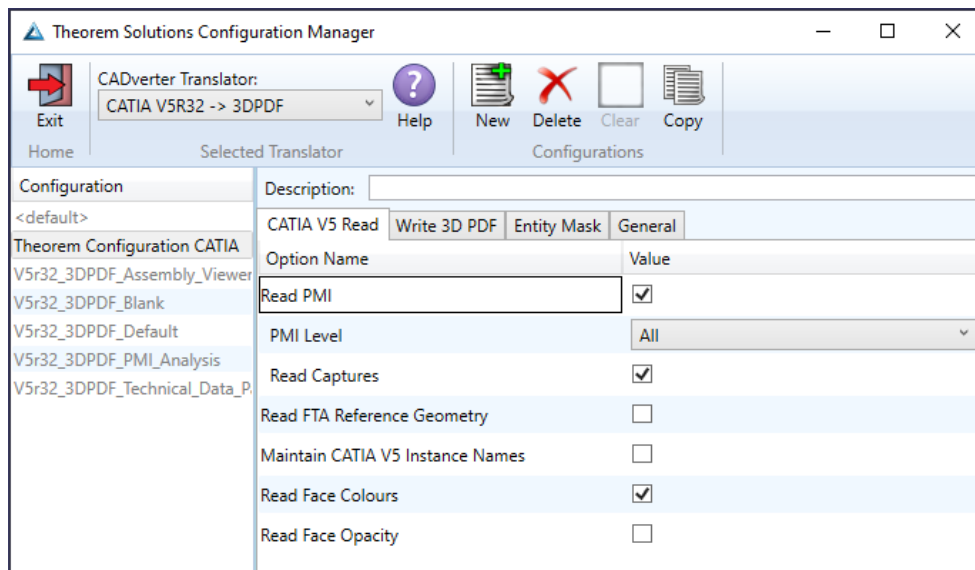

Each of the options displayed in the image above are described below:

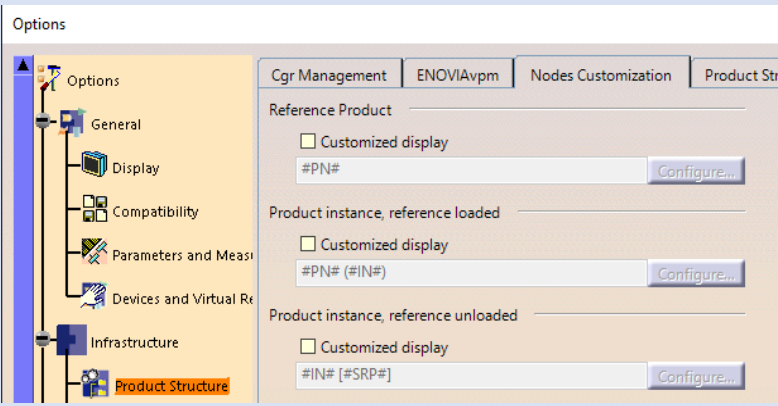
Option	Description
<p>Read PMI</p>	<p>Enables PMI data read (Default is ON.) Command Line Syntax:</p> <ul style="list-style-type: none"> <i>read_pmi – default</i> <i>dont_read_pmi – to turn off</i> <p>Note – When <i>'read_pmi'</i> is enabled it also enables the <i>'fill_pmi_arrows'</i>, <i>'fill_pmi_text'</i> and <i>'pmi_filled_text'</i> options. These can be overridden by setting the Advanced arguments <i>'dont_fill_pmi_arrows'</i> and/or <i>'dont_fill_pmi_text'</i></p>
<p>PMI Level</p>	<p>A secondary argument to 'Read PMI' and allows control of the level of PMI to be read. Default is ALL when 'Read PMI' is marked as ON.</p> <p>Options Available (command line syntax in italics and square brackets.)</p> <ul style="list-style-type: none"> All - [<i>read_pmi</i>] Part Level - [<i>read_part_pmi</i>] Assembly Level - [<i>read_assy_pmi</i>] Assembly Set (From CATPart) - [<i>read_part_assy_pmi</i>] Assembly Set (All) - [<i>read_all_assy_pmi</i>]
<p>Read Captures</p>	<p>A secondary argument to 'Read PMI' and allows control over whether captures are read as part of the process. Default is ON when 'Read PMI' is marked as ON. Captures can ONLY be read when 'Read PMI' is ON.</p> <p>Command Line Syntax:</p> <ul style="list-style-type: none"> <i>read_captures – default</i> <i>dont_read_captures – to turn off</i>
<p>Read FTA Reference Geometry</p>	<p>Enables reading of FTA Reference Geometry. (<i>Default is Off</i>). FTA Reference Geometry can ONLY be read when 'Read PMI' is ON.</p> <p>Command Line Syntax:</p> <ul style="list-style-type: none"> <i>read_geometry – to turn on</i>
<p>Maintain CATIA V5 Instance Names</p>	<p>Honours CATIA V5 <i>Tools->Options->Infrastructure->Product Structure>Nodes Customization</i> panel settings. (<i>Default is Off</i>.)</p>  <p>Command Line Syntax:</p> <ul style="list-style-type: none"> <i>ditto_naming V5 – to turn on</i>

Read Face Colours	Read the face colours. <i>(Default is on.)</i> Command Line Syntax: <ul style="list-style-type: none">• <i>read_face_colours – default</i>• <i>no_face_colours – to turn off</i>
Read Face Opacity	Read the opacity of the face. <i>(Default is off.)</i> Command Line Syntax: <ul style="list-style-type: none">• <i>read_materials – to turn on</i>

Write 3D PDF

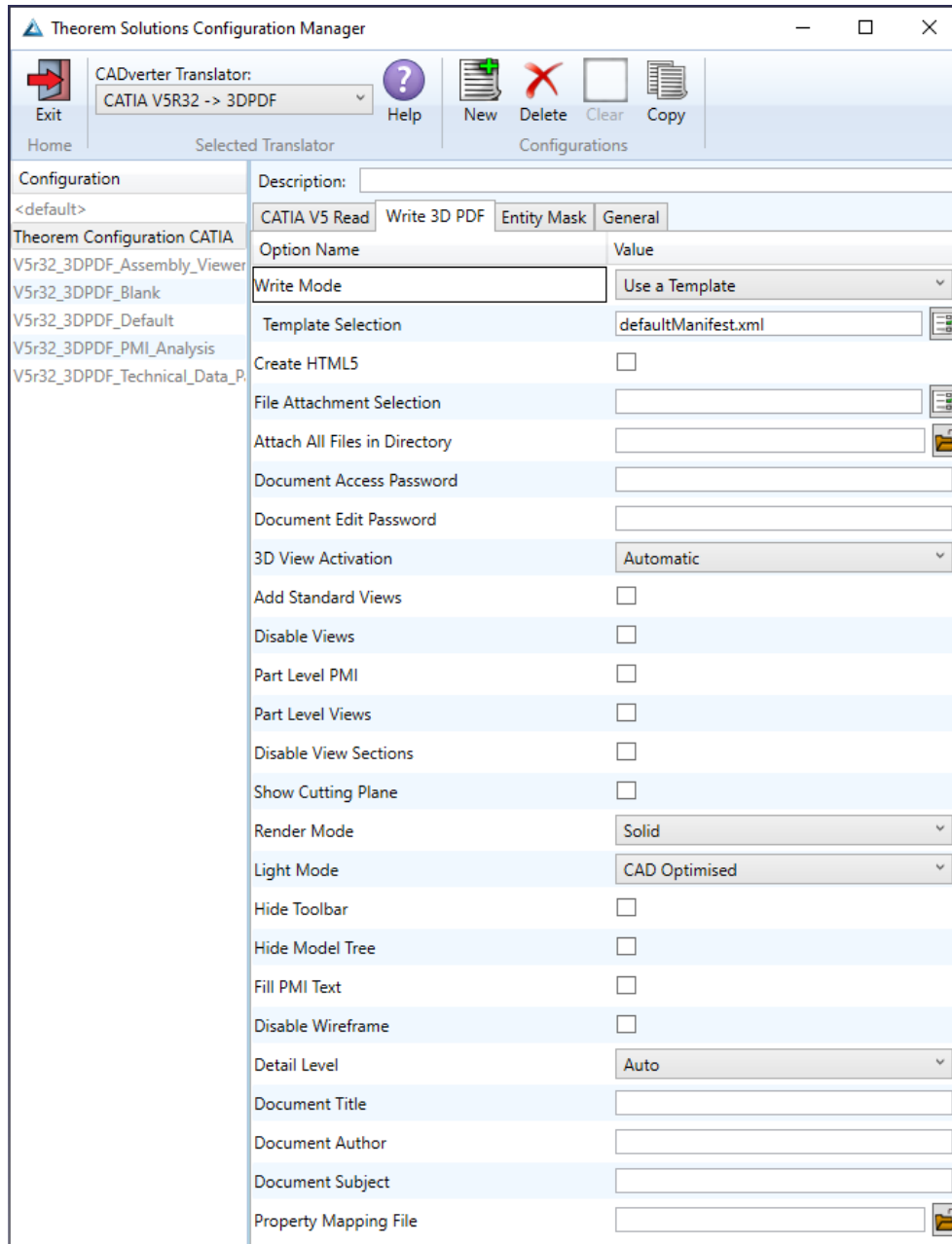

Each of the options displayed in the image above are described below:

Option	Description
Write Mode	Contains two options: <ul style="list-style-type: none"> – Use a Template – Allows data to be published to a given template Command Line Syntax: <ul style="list-style-type: none"> • <i>publish <XML Manifest file></i> – No Template – No template will be used during publishing. If this option is selected, 'Template Selection' is excluded as an option. Command Line Syntax: <ul style="list-style-type: none"> • <i>publish off</i>
Template Selection	Select which templates Publish 3D will use to create the output 3D PDF, if Write Mode is set to <i>Use a Template</i> (Default = defaultManifest.xml.) Command Line Syntax: <ul style="list-style-type: none"> • <i>This is a secondary argument to the publish command. The argument can be a single xml manifest file or a text file containing a list of manifest files</i>
File Attachment Selection	This option allows files to be attached to the output PDF file together with a brief description of the selected files. (Default is for no files to be attached.) Command Line Syntax: <ul style="list-style-type: none"> • <i>attach_file <Attachment List></i> <p>Where <i><Attachment_List></i> is a text file, with a list of full path names followed by an optional description line, For example:</p> <pre style="text-align: center;"> C:\TEMP\my_image.jpg This is a jpg Image C:\TEMP\report.txt Report Document C:\TEMP\related.pdf C:\TEMP\another.pdf This PDF has a description </pre> <p><i>Note in this example the 'Related.pdf' attached file doesn't have the optional comment.</i></p> <p><i>The file path may contain environment variables which will be resolved. e.g. %TEMP%/myFile.pdf</i></p>
Attach All Files in Directory	Attach ALL files found in a specified directory. Command Line Syntax: <ul style="list-style-type: none"> • <i>attach_files_in_dir <dir></i> <p>Where <i><dir></i> is the location of the files.</p>
Document Access Password	Contains two options selectable via a checkbox:

	<ul style="list-style-type: none"> – No Password – Specifies that no password will be used to encrypt the PDF Document (Default). If this option is selected Password is excluded as an option. Command Line Syntax: <ul style="list-style-type: none"> • <i>no entry required</i> – Use Password – Allow a password to be specified to encrypt the PDF document. If specified, the user will be prompted for the password to open the resultant PDF files. Command Line Syntax: <ul style="list-style-type: none"> • <i>password <password></i>
Document Edit Password	Contains two options selectable via a checkbox: <ul style="list-style-type: none"> – No Password – Specifies that no password will be used to controls edits to the PDF Document (Default). If this option is selected Password is excluded as an option. Command Line Syntax: <ul style="list-style-type: none"> • <i>no entry required</i> – Use Password – Allow a password to be specified to controls edits to the PDF Document. Command Line Syntax: <ul style="list-style-type: none"> • <i>permission_password <password></i>
3D View Activation	Controls when the 3D view is activated in the PDF document. Has 3 options: <ul style="list-style-type: none"> – Automatic – Activates when the page is opened. (Default) Command Line Syntax: <ul style="list-style-type: none"> • <i>activate_mode PAGE_OPEN</i> – On Selection – Activates when the user clicks on the model. Command Line Syntax: <ul style="list-style-type: none"> • <i>activate_mode CLICK (default via the command line)</i> – Page Visible – Activates when the page becomes visible to the user Command Line Syntax: <ul style="list-style-type: none"> • <i>activate_mode PAGE_VISIBLE</i>
Add Standard Views	Add isometric views to the data being written to PDF (Default is off.) Command Line Syntax: <ul style="list-style-type: none"> • <i>add_standard_views</i>
Disable Views	Switch off any Captures/Views from being written into the PDF. (Default is off.) Command Line Syntax: <ul style="list-style-type: none"> • <i>no_views</i>
Part Level PMI	Enable the processing of PMI on parts within an assembly. (Default is off.) Command Line Syntax: <ul style="list-style-type: none"> • <i>part_level_pmi</i>

Part Level Views	Enable the processing of part level views within an assembly. (Default is off.) Command Line Syntax: <ul style="list-style-type: none"> • <i>part_level_views</i>
Disable View Sections	Switch off any sections within the Captures/Views from being written into the PDF. (Default is off.) Command Line Syntax: <ul style="list-style-type: none"> • <i>no_sections</i>
Show Cutting Plane	Enable cut plane visualisation. (Default is off.) Command Line Syntax: <ul style="list-style-type: none"> • <i>cutplane_on</i>
Render Mode	Controls which Rendering Mode to use for the model. Options are: <ul style="list-style-type: none"> • Solid (Default) • Transparent • Wireframe • Illustrated • Outline • Shaded Command Line Syntax: <ul style="list-style-type: none"> • <i>render_mode <mode></i> Where <i><mode></i> is set to one of the above values.
Light Mode	Controls which Light Mode to use. Options are: <ul style="list-style-type: none"> • Default • Off • Day • Bright • Prim • Night • Blue • Red • Cube • Head Command Line Syntax: <ul style="list-style-type: none"> • <i>light_mode <mode></i> Where <i><mode></i> is set to one of the above values. Note – no command is required for the default value.

Hide Toolbar	Hide the 3D Toolbar in the resultant document. This can be re-enabled in Adobe if required. (Default is off.) Command Line Syntax: <i>hide_toolbar</i>
Hide Model Tree	Hide the Model Tree in the resultant document. This can be re-enabled in Adobe if required. (Default is off.) Command Line Syntax: <i>hide_model_tree</i>
Disable Wireframe	Disable Wireframe Processing (Default is to Enable Wireframe processing.) Command Line Syntax: <i>process_wf off</i>
Detail Level	<p>The Detail Level option can be used to set the render quality of the resultant 3D PDF output. A number of discrete values are made available via the configuration manager. They correspond to a relative chordal deviation (% of the diagonal length across the model bounding box) or absolute chordal deviation, whichever is the smaller. The following options are available:</p> <ul style="list-style-type: none"> • Auto (Corresponds approximately to High) • Very High (relative = 0.0001%, absolute = 0.001mm) • High (relative = 0.001%, absolute = 0.01mm) • Medium (relative = 0.01%, absolute = 0.1mm) • Low (relative = 0.1%, absolute = 1mm) • Very Low (relative = 0.5%, absolute = 5mm) <p>For very large (detailed) parts the use of the options Low or Very Low can significantly reduce the size of the output PDF file and the time taken to produce it, at the cost of quality.</p> <p>A setting of Medium is seen as a good compromise, between quality and size. This value is the default value.</p> <p>Command Line Syntax:</p> <ul style="list-style-type: none"> • <i>lod_level <value></i> <p>Where value = v_low, low, med, high, v_high, off</p>
Document Title	Set the Document Properties 'title' field. Command Line Syntax: <ul style="list-style-type: none"> • <i>doc_description_title <"text"></i> the text should be quoted.
Document Author	Set the Document Properties 'author' field. Command Line Syntax: <ul style="list-style-type: none"> • <i>doc_description_author <"text"></i> the text should be quoted.

Document Subject	Set the Document Properties 'subject' field. Command Line Syntax: <ul style="list-style-type: none">• <code>doc_description_subject <"text"></code> the text should be quoted.
-------------------------	---

Property Mapping file	Map CAD properties using a mapping file. Command Line Syntax: <code>cad_prop_map_file <file></code>
------------------------------	---

Entity Mask

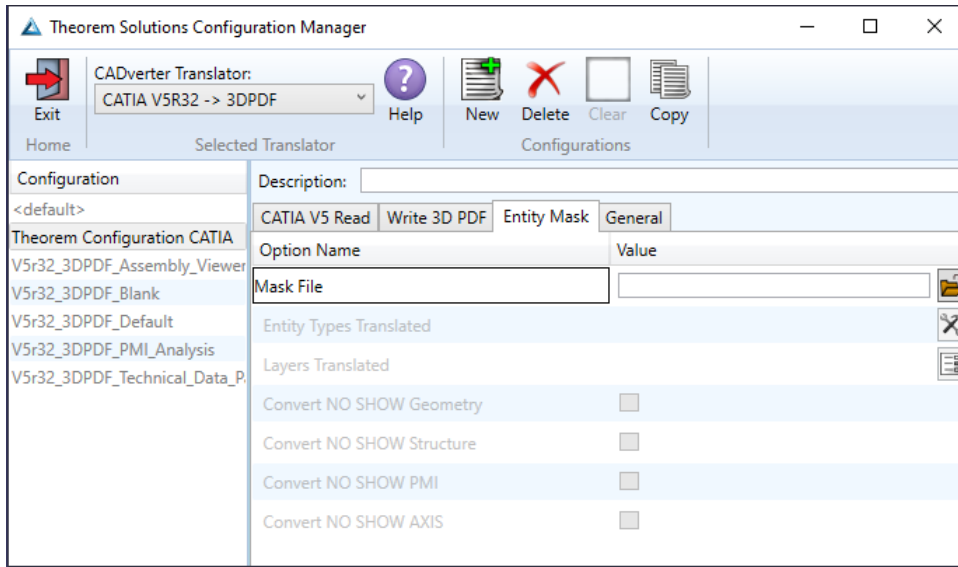

Each of the options displayed in the image above are described below:

Option	Description
Mask File	Specifies the Mask File to be written to, that can be referenced by future translations. A Mask file MUST be specified if masking is required. The first line in this file is OFF ALL ENT. Command Line Syntax: <ul style="list-style-type: none"> • <i>mask <filename></i>
Entity Types Translated	Specifies a selection list from which to select the entity types that are to be processed. The following types are available: "SOL" – Masks any 3D entity "SKIN" – Masks any 2D entity "CUR" – Masks any 1D entity "POI" – Masks any 0D entity "AXIS" – Masks Axis Systems "ISOL" – Masks Isolated faceted solids "CCRV" – If on creates a CCRV curve for wire frame edges that have more than one supporting curve "TEXT" – Masks PMI Text Command Line Syntax: <ul style="list-style-type: none"> • <i>Add any of the above to the specified mask file, one entry per line prefixed by the word ON, e.g. ON POI</i>
Layers Translated	Specifies a selection list from which to select the layers that are to be processed. Command Line Syntax: <ul style="list-style-type: none"> • <i>A single entry of ON ALL LAY Must precede any Layer Mask command. Add a list or range of numbers representing the layers to be processed to the specified mask file to ensure they are NOT considered in the translation e.g. OFF LAY 114,149,166,167,168</i>
Convert NO SHOW Geometry	Enables Hidden geometry to be processed. <i>(Default is Off.)</i> Command Line Syntax: <ul style="list-style-type: none"> • ON NOSHOW GEO – Add to the Mask file
Convert NO SHOW Structure	Enables Hidden Assembly Structure to be processed. <i>(Default is Off.)</i> Command Line Syntax: <ul style="list-style-type: none"> • ON NOSHOW STR – Add to the Mask file
Convert NO SHOW PMI	Enables Hidden PMI to be processed. <i>(Default is Off.)</i> Command Line Syntax: <ul style="list-style-type: none"> • ON NOSHOW PMI – Add to the Mask file
Convert NO SHOW AXIS	Enables Hidden Axis Systems to be processed. <i>(Default is Off.)</i> Command Line Syntax: <ul style="list-style-type: none"> • ON NOSHOW AXI – Add to the Mask file

General

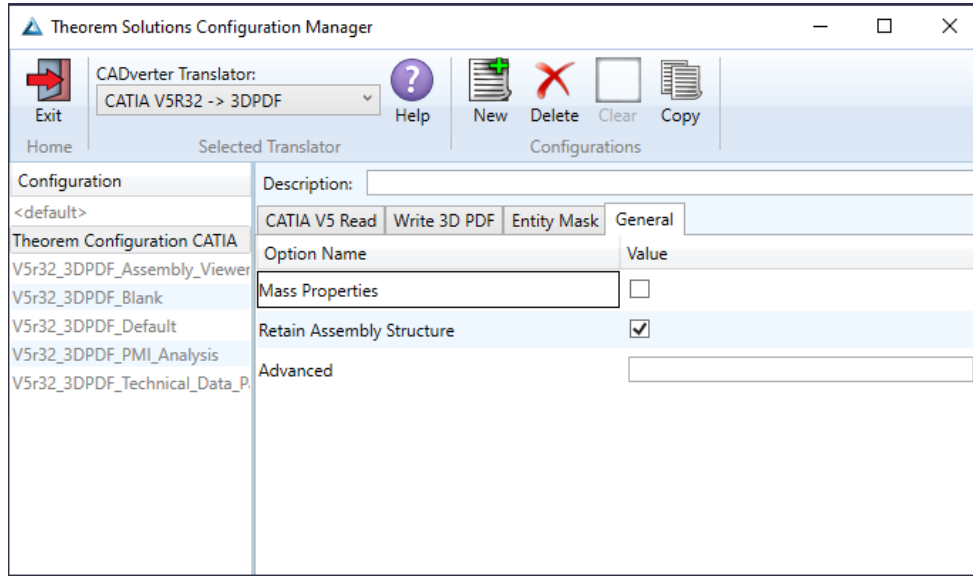

Each of the options displayed in the image above are described below:

Option	Description
Mass Properties	Allows mass property information to be read. Command line syntax: <ul style="list-style-type: none"> <i>mprops</i>
Retain Assembly Structure	Enables Assembly Structure to be retained. (<i>Default is On</i>) Disabling this option will remove all assembly structure and collapse ALL geometry into a single selectable object. Command line syntax: <ul style="list-style-type: none"> <i>off_ditto</i> – to turn off
Advanced	Allows any of the advanced arguments documented to be added to the configuration manager and applied during translation.

Advanced Arguments

CATIA V5 Advanced Arguments

Argument	Description
<i>axis_systems on / value</i>	<p>The axis_systems on option controls the reading of CATIA V5 axis system definitions. The axis system is recreated using 3 wireframe lines. The lines will be coloured RED, GREEN & BLUE to represent the X,Y & Z direction and will extend from the XOY0Z0 of the axis system. The default length of the lines will be 1" or 25.4 mm depending upon the units of the file.</p> <p>The length of the output graphical representation can be controlled by using a value for the axis_systems option e.g. axis_systems 100 would create the lines at 100 units in length of the units of the input file.</p>
<i>convert_curves</i>	Converts curves to NURBS form.
<i>convert_surfaces</i>	Converts surfaces to NURBS form.
<i>dont_fill_pmi_arrows</i>	Disables the read of filled arrow information. <i>(Default for 'read_pmi'.)</i>
<i>dont_fill_pmi_text</i>	Disables the read of filled text information. <i>(Default for 'read_pmi'.)</i>
<i>noshow noshow_geom noshow_struct noshow_pmi</i>	Reads hidden geometry / structure / PMI.
<i>output_mbd</i>	Allows sub-part specification tree information to be read and presented to 3D PDF as product structure information. This option also enables the ' part_level_views ' and ' part_level_pmi ' 3D PDF options.
<i>output_mbd_leaf_nodes</i>	Allows an extra level of the specification tree structure to be read. This option also enables the ' part_level_views ' and ' part_level_pmi ' 3D PDF options.
<i>read_geometry_edges</i>	CATIA V5 has a display mode that allows the display of shaded surfaces and edges. This option allows the translator to mimic this for FTA construction geometry by promoting the edge curves to standalone wireframe.

3DPDF Advanced Arguments

Argument	Description
<i>use_part_names</i> <on/off>	When 'on' the 3DGeom node names are replaced by the TAG name from the detail (part name). <i>Default is off.</i>
<i>progress_file</i> <filename>	Specify the log file for this process.
<i>info</i>	Add 'info' messages to the log file.
<i>no_inst_colours</i>	Switch off the writing of instance colours.
<i>no_colours</i>	Switch off the writing of any colours.
<i>no_attrs</i>	Switch off the writing of attributes into the PDF.
<i>no_pmi_edge_associations</i>	Disables edge highlighting.
<i>no_poster</i>	By default, a 2D poster is generated from the 3D model which can be very time consuming for a complex model. This option disables that process and uses a default JPG called TS_INST\\data\saveas_3dpdf_images\no_poster.jpg . The user could replace this JPG file with their own if desired.
<i>background_RGB</i> <r g b>	Where r g b are values 1 to 255, this controls the background colour of the 3D display, which now defaults to pale grey (204,204,204).
<i>pmi_RGB</i> <r g b>	Where r g b are values 1 to 255, this controls the override PMI colour. By default, PMI is displayed in the same colour as the source CAD system. When a colour is not read the default will be black. This option allows the PMI colour to be fixed to any colour, clearly this is a single override colour for all PMI.
<i>wireframe_RGB</i> <r g b>	Where r g b are values 1 to 255, this controls the override PMI colour. By default, wireframe is displayed in the same colour(s) as the source CAD system. This option allows the wireframe colour to be fixed to any colour, clearly this is a single override colour for all PMI.

<p>pmi_flat_to_screen <on/all/off></p>	<p>This option enables the processing of flat to screen PMI data, the default is off. Please note fonts are not currently supported.</p> <p>'on' allows for FLAT TO TEXT types to be processed 'all' allows all FLAT TO SCREEN types to be process, however only the text and NOT the frames are processed.</p>										
<p>process_wf <value></p>	<p>Where value = tess_low, tess_med, tess_high, nurb or off</p> <p>When this option is selected the wireframe entities are written as lines/conic/nurbs. This results in a wire node for each entity contained under the Wireframe node in the model tree, there could be many wire nodes in a complex model.</p> <p>If any of the settings prefixed tess are used, these options convert wireframe into a number of sampled points on the curve and writes wireframe as a Poly Line, this allows many wires to be combined however a Poly Line can only be a single colour, so wireframe of the same colour will be grouped into a Poly Wire, which will be a wire node contained under the Wireframe node in the model tree. There will be a wire node for each colour, when multi colours exist.</p> <p>If however, all wireframe is the same colour, then all wireframe is contained in the Wireframe node.</p>										
<p>attr_filter_file <filter file></p>	<p>This is a method to define which attributes are masked or included during translation.</p> <p>By default, there is an attribute filter file installed at: %TS_INST%\ data\publish_3dpdf\attrFilters\ defaultAttrFilter.txt</p> <p>This command line option allows this file to be overridden, such that the named file is used instead of the default.</p> <p>The file format (in blue) is best explained by means of examples:</p> <table border="0" data-bbox="539 1451 1369 1675"> <tr> <td>MPARTNAME,,0,,</td> <td>(Delete MPARTNAME attribute)</td> </tr> <tr> <td>FILENAME,FILE (name),1,,</td> <td>(Rename 'FILENAME' to 'FILE (name))</td> </tr> <tr> <td>FILESIZE,,3,big,,</td> <td>(Default (always) FILESIZE value to big)</td> </tr> <tr> <td>*END,,0,,</td> <td>(Delete all attributes that end with 'END')</td> </tr> <tr> <td>Theorem*,,0,,</td> <td>(Delete all attributes that start with 'Theorem')</td> </tr> </table>	MPARTNAME,,0,,	(Delete MPARTNAME attribute)	FILENAME,FILE (name),1,,	(Rename 'FILENAME' to 'FILE (name))	FILESIZE,,3,big,,	(Default (always) FILESIZE value to big)	*END,,0,,	(Delete all attributes that end with 'END')	Theorem*,,0,,	(Delete all attributes that start with 'Theorem')
MPARTNAME,,0,,	(Delete MPARTNAME attribute)										
FILENAME,FILE (name),1,,	(Rename 'FILENAME' to 'FILE (name))										
FILESIZE,,3,big,,	(Default (always) FILESIZE value to big)										
*END,,0,,	(Delete all attributes that end with 'END')										
Theorem*,,0,,	(Delete all attributes that start with 'Theorem')										
<p>dump_attr_file <file></p>	<p>This is a utility which can be used to generate a text file with the Key/Value pairs from the GCO DESIGN, DITTO and DETAIL entities, this can be used in the 'design' of templates.</p>										
<p>hide_empty_node</p>	<p>When assembly nodes contain no geometry, (could be due to missing part files) this option results in the model tree with 'un-ticked' nodes where no geometry was read. Where the 3DGeom node would be, there will be a NoGeom node instead.</p> <p>Please node in order to activate this behaviour it was necessary to add a point at 0,0,0 which is contained by the NoGeom node.</p>										

<i>compress_tess <value></i>	<p>Where value = v_low, low,med, high ,v_high, off</p> <p>These options can be used to control the tessellation setting, using the values 10, 25, 50, 75, 90. These compression settings apply ONLY to PRC/U3D output files.</p>
<i>add_standard_views_1st</i>	<p>Force views to be first angle projection regardless of source data.</p>
<i>add_standard_views_3rd</i>	<p>Force views to be third angle projection regardless of source data.</p>
<i>views_filter <val></i>	<p>This option allows a sub-set of views to be included in the output based upon the <val> which describes a part or all of the views name(s). For example:</p> <p>views_filter MBD_* = Includes all views with names beginning 'MBD_' views_filter *SECTION = Includes all views with names ending in 'SECTION' views_filter BLUE = Includes all views with names containing 'BLUE'</p> <p>Multiple filters can also be applied by adding any number of views_filter arguments. For example:</p> <p>views_filter A* views_filter *B views_filter FRED – Includes views that start with an 'A' or end in a 'B'. Views named 'FRED' will also be included.</p>
<i>views_filter_exclude <val></i>	<p>This option allows a sub-set of views to be excluded from the output based upon the <val> which describes a part or all of the views name(s). For example:</p> <p>views_filter_exclude MBD_* = Excludes all views with names beginning 'MBD_' views_filter_exclude *SECTION = Excludes all views with names ending in 'SECTION' views_filter_exclude BLUE = Excludes all views with names containing 'BLUE'</p> <p>Multiple filters can also be applied by adding any number of views_filter_exclude arguments. For example:</p> <p>views_filter_exclude A* views_filter_exclude *B views_filter_exclude FRED – Excludes views that start with an 'A' and end in a 'B'. Views named 'FRED' will also be excluded.</p> <p>Note – It is possible to use both include and exclude filters in the same translation. For Example</p> <p>views_filter A* views_filter_exclude AXEL – Includes views that start with an 'A' but excludes views named 'AXEL'</p>

<p><i>add_meta_data</i> <default or <file>></p>	<p>Option to append the attributes in PDF with useful data, like part count, which can be consumed by the templates.</p> <p><default> - just add part count <file> - add the part count and process the file, such that 3 lines are processed.</p> <pre> part_name // matches the detail (part name) attr_name // name of attribute to be added attr_value // value of the attribute to be added </pre>
<p><i>move_subassy_pmi</i> <on/off/all></p>	<p>Move the sub assy PMI to top level.</p> <p>"all" will reposition all PMI into global space which can be used for true assemblies.</p>
<p><i>copy_part_attrs</i> <on/off></p>	<p>Attributes on parts can be copied on to instance nodes with this option (default is off). (The user can enable dump_attr_file <file> option to confirm what attributes are available on part/instances, to check the effect of this option.)</p>
<p><i>cutplane_capping_off</i></p>	<p>Disable section capping (Default is on.)</p>
<p><i>cutplane_RGB</i> <r g b></p>	<p>When section cutting planes are enabled, the cutting plane colour can be controlled by r g b values in the range of 1 to 255.</p>
<p><i>cutplane_opacity</i> <val></p>	<p>When section cutting planes are enabled, the cutting plane opacity can be specified by setting 'val' between 0.0 and 1.0.</p>
<p><i>cutplane_intersections</i></p>	<p>Section cutting intersections can be enabled via this option. (Default is off.)</p>
<p><i>cutplaneIS_RGB</i> <r g b></p>	<p>When section cutting plane intersections are enabled, the cutting plane intersection colour can be controlled by r g b values in the range of 1 to 255.</p>
<p><i>enable_brep</i></p>	<p>By default, BREP data is omitted when the PDF file is generated so this option allows for such data to be retained.</p> <p>Do not use this option when the generation of BREP data in PDF is forbidden for legal or commercial reasons.</p>
<p><i>fixup</i></p>	<p>There are occasions when the source data presented for publishing to the 3D PDF is invalid. In these circumstances, a validation of the data is carried out by the translator and the user is advised, via a message on the screen to re-run the translator, specifying the 'fixup' command line option. Specifying this option will allow the translation to complete, omitting any faces that are not topologically correct.</p>

<i>fix_inst_names <on/off></i>	<p>By default, this option is on. It will detect instances with no names and apply the part name to those instances. This accommodates cases where instance names are not available in the source data.</p>
<i>launch_adobe_viewer</i>	<p>This option will automatically display the resulting PDF file in an Adobe Reader. The environment variable TS_CMD_PATH_AND_EXE can be used to specify the Adobe application if it isn't found in a default location.</p>
<i>group_solids</i>	<p>This can be useful when data is created with many open solids (1 per face). This can result in many 100's or even 1000's of solids which causes the 3D PDF file to have a massive entity tree, to be slower and larger than necessary, and with a Bounding Box for each face.</p> <p>Setting this option groups the solids into logical entities.</p>
<i>dont_group_solids</i>	<p>Some systems will group solids by default, so this option allows that setting to be disabled.</p>
<i>invisible <on or off></i>	<p>Wireframe entities that are marked as invisible are by default NOT processed. This option allows them to be processed.</p>
<i>pmi_assoc_limit <off or number></i>	<p>This option is used to limit the number of PMI to Geometry associations that exist for any single PMI node. The default value being 500.</p> <p>It has been found that in rare cases many 1000's of associations exist and this has a significant effect on the translation time. If the limit is exceeded the log file reports the PMI entities names and reports an error, allowing the user to modify the limit, or review the PMI's validity.</p>
<i>set_perm <text option></i>	<p>Set the permissions for the PDF file, the options being "PRINT" or "LOCK", if no options are set then the create PDF file is fully open.</p> <p>The "PRINT" setting allows the file ONLY to be printed. The "LOCK" setting ensures the document cannot be modified.</p> <p>(Be aware that with Adobe Writer it is possible to override any permission setting).</p>
<i>set_perm_mask <int value></i>	<p>This allows the full control of all the permission settings when creating a PDF file, the in values need to be logically ORed together so 0x2 and 0x1 become 3. values are 0xHex (decimal)</p> <p>0x01 (1) - DocumentPermOpen The user can open and decrypt the document.</p> <p>0x02 (2) - DocumentPermSecure The user can change the document's security settings.</p> <p>0x04 (4) - DocumentPermPrint The user can print the document. Page Setup access is unaffected by this permission, since that affects Acrobat's preferences - not the document's. In the Document Security dialog, this corresponds to the Printing entry.</p>

0x08 (8) - **DocumentPermEdit** The user can edit the document more than adding or modifying text notes (see also DocumentPermEditNotes). In the Document Security dialog, this corresponds to the Changing the Document entry.

0x10 (16) - **DocumentPermCopy** The user can copy information from the document to the clipboard. In the document restrictions, this corresponds to the Content Copying or Extraction entry.

0x20 (32) - **DocumentPermEditNotes** The user can add, modify, and delete text notes (see also DocumentPermEdit). In the document restrictions, this corresponds to the Authoring Comments and Form Fields entry.

0x40 (64) - **DocumentPermSaveAs** The user can perform a Save As.... If both DocumentPermEdit and DocumentPermEditNotes are disallowed, Save will be disabled but 'Save As...' will be enabled. The 'Save As...' menu item is not necessarily disabled even if the user is not permitted to perform a Save As...

0x100 (256) - **DocumentPermFillandSign** Overrides other DocumentPerm bits. It allows the user to fill in or sign existing form or signature fields.

0x200 (512) - **DocumentPermAccessible** Overrides DocumentPermCopy to enable the Accessibility API. If a document is saved in Rev2 format (Acrobat 4.0 compatible), only the DocumentPermCopy bit is checked to determine the Accessibility API state.

0x400 (1024) - **DocumentPermDocAssembly** Overrides various DocumentPermEdit bits and allows the following operations: page insert/delete/rotate and create bookmark and thumbnail.

0x800 (2048) - **DocumentPermHighPrint** This bit is a supplement to DocumentPermPrint. If it is clear (disabled) only low quality printing (Print As Image) is allowed. On UNIX platforms where Print As Image doesn't exist, printing is disabled.

0x8000 (32768) - **DocumentPermOwner** The user is permitted to perform all operations, regardless of the permissions specified by the document. Unless this permission is set, the document's permissions will be reset to those in the document after a full save.

0x10000 (65536) - **DocumentPermFormSubmit** This should be set if the user can submit forms outside of the browser. This bit is a supplement to DocumentPermFillandSign.

0x20000 (131072) - **DocumentPermFormSpawnTempl** This should be set if the user can spawn template pages. This bit will allow page template spawning even if DocumentPermEdit and DocumentPermEditNotes are clear.

0xFFFFFFFF - All permissions.

<p><i>expand_part</i></p>	<p>This option creates a pseudo assembly structure below a part, such that each solid is modelled by a separate node. The default is to combine all solids that belong to the same part.</p> <p>Using this option can be useful when control over part with multiple solids is required, e.g. view/hide separate solids, however it should be noted that this option may compromise other functionality, such as PMI association.</p>
<p><i>zoom_views_x <value></i></p>	<p>This option will magnify the view by the value provided, this is defaulted to 2.0 for all CAD systems.</p> <p>Values < 1.0 zoom out. Values > 1.0 zoom in.</p> <p>The purpose of this option is to expose an adjustment factor that a given CAD system might need to best fit the VIEWS in the PDF, this may be affected by the aspect ratio of the page size/template used in PDF write.</p> <p>Every effort has been made to set a good value by default.</p>
<p><i>optimize_save off</i></p>	<p>By default, the PDF will be automatically optimized to make the file smaller. This disables the optimization feature.</p>
<p><i>image_dir <directory></i></p>	<p>Import images into a template from a directory.</p>
<p><i>axis_systems <on>/auto/<size in mm></i></p>	<p>Enables the output of axis systems to the PDF. Default is on. The Default value when on is 25mm. When enabled wireframe x(RED),y(GREEN),z(BLUE) are created to represent the axis system location.</p> <p>Using auto will enable the size of the axis system to be generated based upon the bbox within a 5-25mm range.</p> <p>The length of the axis system can also be given in mm, e.g. axis_systems 100 which specifies a length of 100mm for example.</p>
<p><i>ts_cfile <text file></i></p>	<p>This option allows command line arguments to be placed in a text file, with one command or option line per line, for example:</p> <pre> read_pmi dont_fill_pmi_text disable_points pmi_RGB 255 1 1 wireframe_RGB 255 1 1 </pre> <p>Note – the progress_file <file> option cannot be added into the text file because the progress file is opened before the command file is read.</p>

<p><i>attach_2D_views <on or WxH></i></p>	<p>It is possible to automatically generate JPG images for each view and attach them to the output PDF file. This is off by default. If it is enabled, then the options are:</p> <p>on - this generated a JPG based upon a WxH of 1600x1200. WxH - allows the image size to be defined e.g. 1200x1800.</p> <p>The view name is prefixed with the input PDF file name to name the image files.</p>
<p><i>attach_2D_views_name_only <on or WxH></i></p>	<p>It is possible to automatically generate JPG images for each view and attach them to the output PDF file. This is off by default. If it is enabled, then the options are:</p> <p>on - this generated a JPG based upon a WxH of 1600x1200. WxH - allows the image size to be defined e.g. 1200x1800.</p> <p>ONLY the view name is used when creating the image files.</p>
<p><i>cutPlane_FIX <x_val y_val z_val></i></p>	<p>This is an option that can be added to resolve section capping issues, where <i>x_val, y_val, z_val</i> are the values that can be added to move the cutplane along the desired axis.</p> <p>For example cutPlane_FIX 0.0 0.2 0.0 will move the cutplane by 0.2mm along the y axis.</p> <p>Negative values can also be added, for example cutPlane_FIX 0.0 -0.2 0.0 will move the cutplane by 0.2mm in the opposite direction along the y axis.</p> <p>Only slight adjustments will typically be required, usually between -0.5 and 0.5. Please note that higher values may be required from time to time.</p>
<p><i>view_part_name</i></p>	<p>Will add the associated part number to the end of the view name, to help make the view names unique. Only required for views at a part level. Only need this argument when 'part_level_views' is also enabled.</p>
<p><i>inst_pmi</i></p>	<p>Allows PMI on multiple part instances in an assembly to be displayed.</p>
<p><i>design_name</i></p>	<p>Names the root node after the TAG attribute in the DESIGN entity. Allows the name of the root node to match the CAD system.</p>

design_naming <format>

Alters the output part name as per the format defined. The format can be defined using the following string values:

Product

- #PN#** - Part Number
- #NO#** - Nomenclature
- #RE#** - Revision
- #SO#** - Source
- #DF#** - Definition
- #DR#** - Description

Link to Reference

- #SRP#** - Short Reference Path

Component

- #IN#** - Instance Name
- #DI#** - Description

Shape

- #SN#** - Shape Name
- #EN#** - Environment
- #SD#** - Short Description
- #SC#** - Source

For example ***design_naming #PN#*** will ensure that the output part name is named the part number specified in the CAD system.

Note – ***design_name*** will also need to be used in conjunction with this argument.

Translating on the Command Line

Default Translation on the Command Line

Running a translation via the command line can be carried out via the **cad_run.cmd** file located in the **<installation_directory>\bin** directory. The format of the command is as follows (Note! Replace the [XX] seen in the example with the version of CATIA V5 you are using. E.g. for V5 R32, change to CATIA532):

<Translator_installation_directory>\bin\cad_run.cmd CATIA5[XX]_3DPDF -i <input_file> -o <output_file>

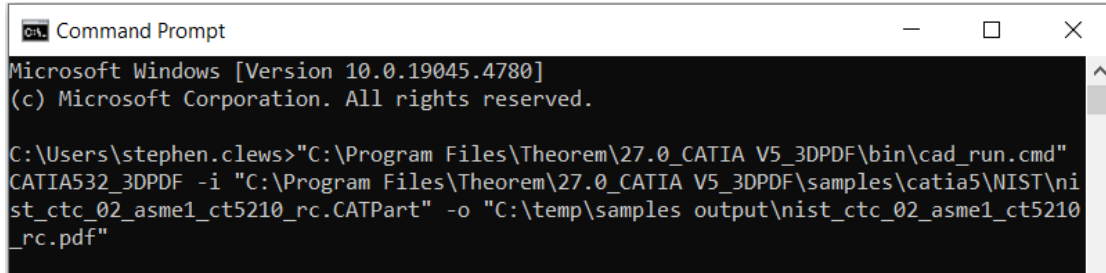

```

ca. Command Prompt
Microsoft Windows [Version 10.0.19045.4780]
(c) Microsoft Corporation. All rights reserved.

C:\Users\stephen.clews>"C:\Program Files\Theorem\27.0_CATIA V5_3DPDF\bin\cad_run.cmd"
CATIA532_3DPDF -i "C:\Program Files\Theorem\27.0_CATIA V5_3DPDF\samples\catia5\NIST\ni
st_ctc_02_asme1_ct5210_rc.CATPart" -o "C:\temp\samples output\nist_ctc_02_asme1_ct5210
_rc.pdf"
    
```

The example above will translate the file to the output location specified. In this case:

C:\temp\samples output\nist_ctc_02_asme1_ct5210_rc.pdf

The following screen output should be expected when successfully translated:

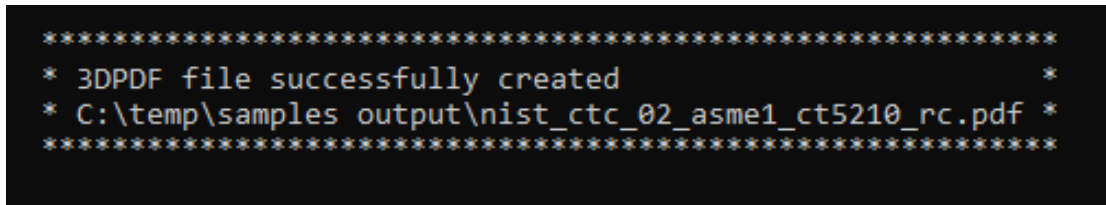

```

*****
* 3DPDF file successfully created *
* C:\temp\samples output\nist_ctc_02_asme1_ct5210_rc.pdf *
*****
    
```

Translating with Options on the Command Line

Options can also be added to a command in the command prompt window using the correct syntax. These are explained in more detail in the Configuration Manager and Advanced Arguments section.

The format of the command with options included is as follows (Note! Replace the [XX] seen in the example with the version of CATIA V5 you are using. E.g. for V5 R32, change to CATIA532):

```
<Translator_installation_directory>\bin\cad_run.cmd CATIA5[XX]_3DPDF -i <input_file> -o <output_file>  
<options>
```

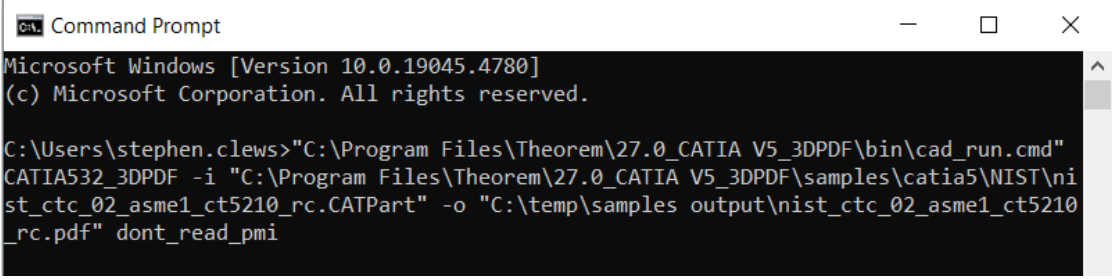

```
Command Prompt
Microsoft Windows [Version 10.0.19045.4780]
(c) Microsoft Corporation. All rights reserved.

C:\Users\stephen.clews>"C:\Program Files\Theorem\27.0_CATIA V5_3DPDF\bin\cad_run.cmd"
CATIA532_3DPDF -i "C:\Program Files\Theorem\27.0_CATIA V5_3DPDF\samples\catia5\NIST\ni
st_ctc_02_asme1_ct5210_rc.CATPart" -o "C:\temp\samples output\nist_ctc_02_asme1_ct5210
_rc.pdf" dont_read_pmi
```

The example above will translate the file with the option(s) specified to the given output location. In this case:

```
C:\temp\samples output\nist_ctc_02_asme1_ct5210_rc.pdf
```

Templates

Publishing to specified Templates – via the Configuration Manager

It is possible to publish to an individual template or multiple templates via one translation run using the Configuration Manager, both interactively and in the Unified Interface. To do this create a new configuration as described earlier or use an existing configuration if one has been created previously. Having a user generated configuration will enable the user to change any of the available options displayed including the template selection. By default, the template selected is defaultManifest.

To change the template, select the **'Write 3D PDF'** tab to display the Write Mode and Template Selection options. Ensure that **'Use a Template'** is selected, then select the  icon next to the Template Selection field.

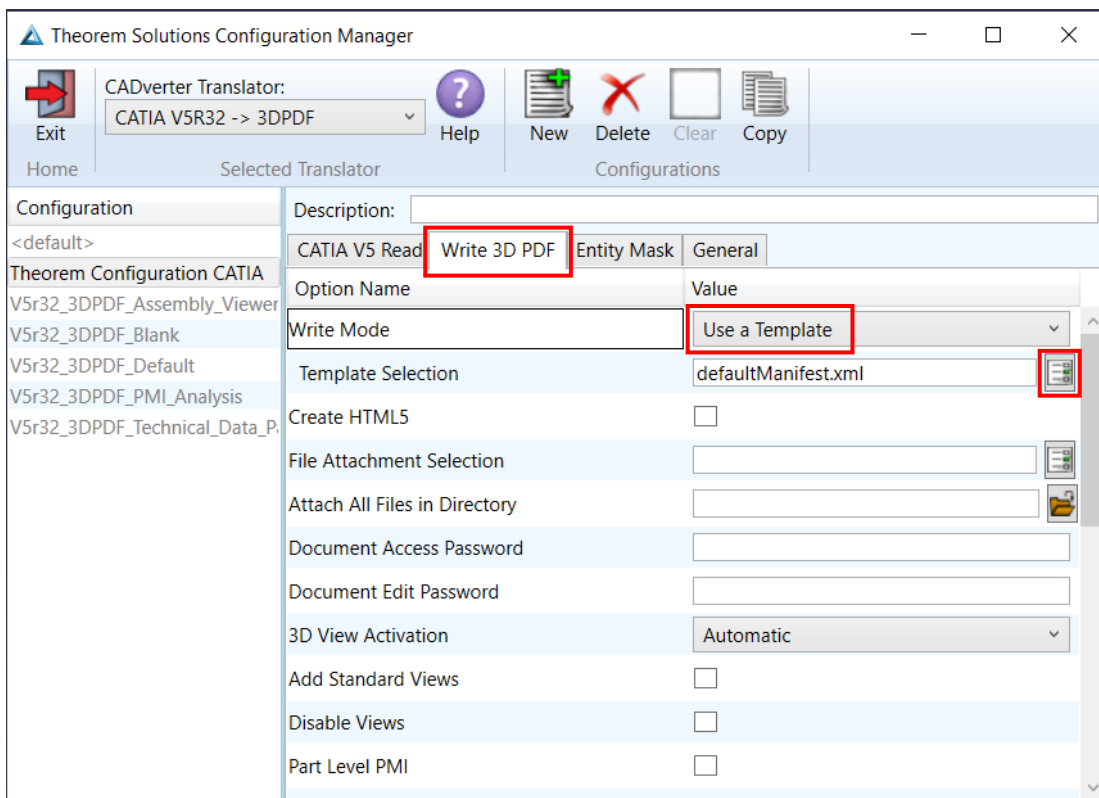

In the Template selection manager window select the  icon. Go to the Required directory and select the template XML file to add it to the list. Click apply to confirm the selection. (Note – This will mean that the data will be translated to this single template)

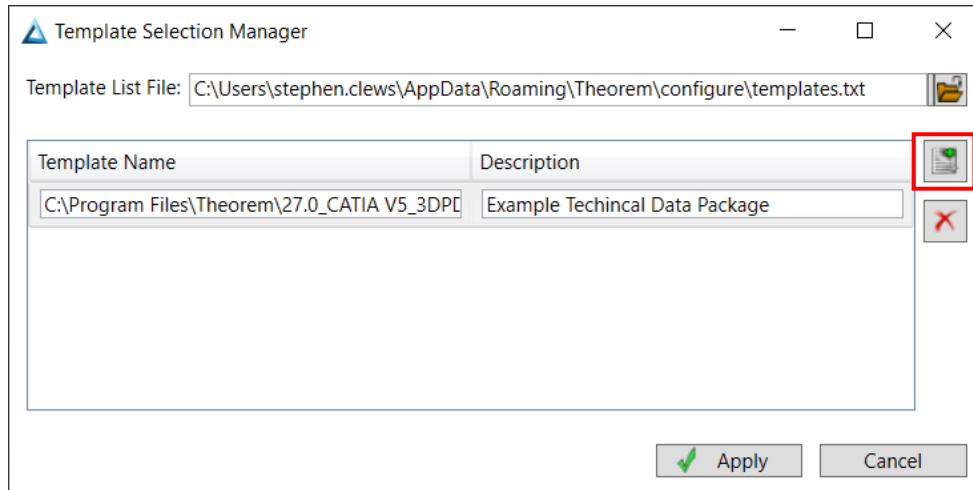

Repeat the process to add more templates if required. Click apply to update the Template Selection. (Note – This will mean that the data will be translated to multiple templates)

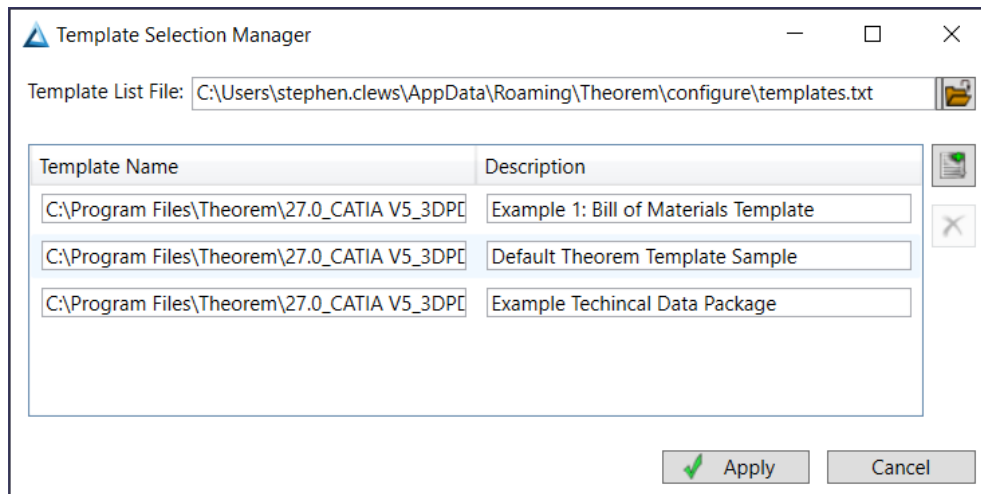

The configuration can then be selected as shown previously and the data translated to PDF. (See ***Translating Interactively from within CATIA V5 and Translating in the Unified Interface.***) This process will create PDF files based upon the template(s) specified.

Publishing to specified Templates – via the Command Line

Publishing to an individual template can be achieved via the command line interface. In order to publish to an individual template a manifest XML file will need to be added to the command in the command prompt window.

The format of the command is as follows (Note! Replace the [XX] seen in the example with the version of CATIA V5 you are using. E.g. for V5 R32, change to CATIA532):

<Translator_installation_directory>\bin\cad_run.cmd CATIA5[XX]_3DPDF -i <input_file> -o <output_file> publish <manifest XML file>

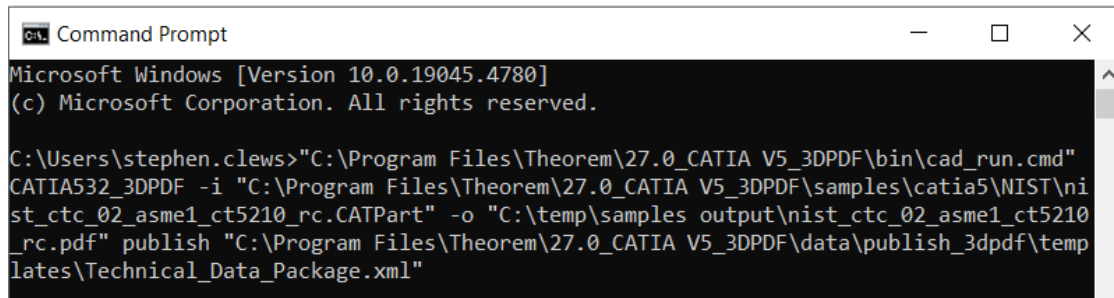

```

Microsoft Windows [Version 10.0.19045.4780]
(c) Microsoft Corporation. All rights reserved.

C:\Users\stephen.clews>"C:\Program Files\Theorem\27.0_CATIA V5_3DPDF\bin\cad_run.cmd"
CATIA532_3DPDF -i "C:\Program Files\Theorem\27.0_CATIA V5_3DPDF\samples\catia5\NIST\nist_ctc_02_asme1_ct5210_rc.CATPart" -o "C:\temp\samples output\nist_ctc_02_asme1_ct5210_rc.pdf" publish "C:\Program Files\Theorem\27.0_CATIA V5_3DPDF\data\publish_3dpdf\templates\Technical_Data_Package.xml"
    
```

The example above will translate the file using the specified template to the given output location, In this case:

C:\temp\samples output\nist_ctc_02_asme1_ct5210_rc.pdf

Publishing to multiple templates can also be achieved via the command line interface. First a text file containing a list of manifest files must be created.

The manifest files should be listed in the following format in the text file:

<Translator_installation_directory>\data\publish_3dpdf\templates\Technical_Data_Package.xml
<Translator_installation_directory>\data\publish_3dpdf\templates\PMI_analysis.xml
<Translator_installation_directory>\data\publish_3dpdf\templates\BOM.xml

Note – Each line points to an individual XML manifest file, examples of which are provided in the translator installation directory.

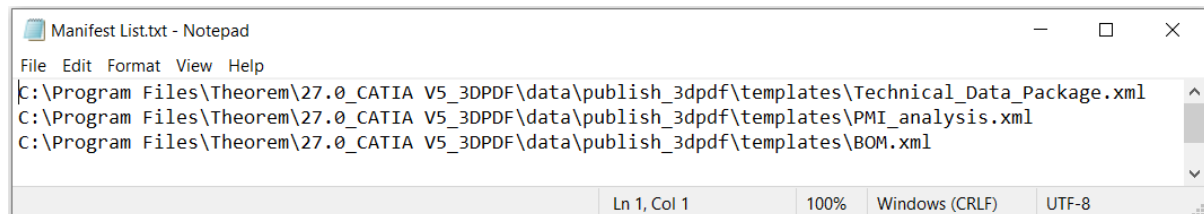

```

Manifest List.txt - Notepad
File Edit Format View Help
C:\Program Files\Theorem\27.0_CATIA V5_3DPDF\data\publish_3dpdf\templates\Technical_Data_Package.xml
C:\Program Files\Theorem\27.0_CATIA V5_3DPDF\data\publish_3dpdf\templates\PMI_analysis.xml
C:\Program Files\Theorem\27.0_CATIA V5_3DPDF\data\publish_3dpdf\templates\BOM.xml
    
```

Once the text file has been created the format for running a command to publish to multiple templates is as follows (Note! Replace the [XX] seen in the example with the version of CATIA V5 you are using. E.g. for V5 R32, change to CATIA532):

<Translator_installation_directory>\bin\cad_run.cmd CATIA5[XX]_3DPDF -i <input_file> -o <output_file> publish <manifest list>

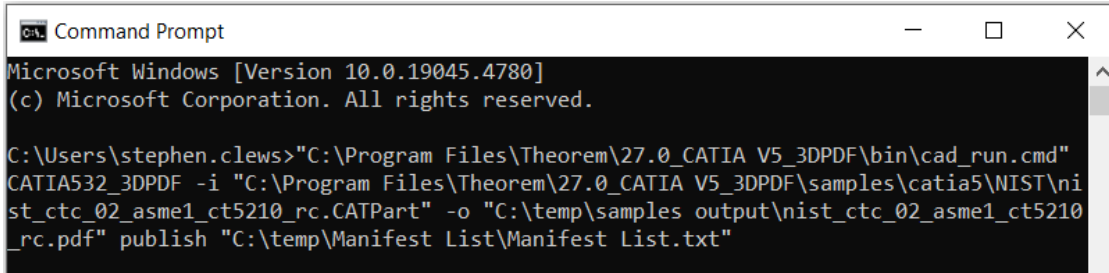

```

C:\> Command Prompt
Microsoft Windows [Version 10.0.19045.4780]
(c) Microsoft Corporation. All rights reserved.

C:\Users\stephen.clews>"C:\Program Files\Theorem\27.0_CATIA V5_3DPDF\bin\cad_run.cmd"
CATIA532_3DPDF -i "C:\Program Files\Theorem\27.0_CATIA V5_3DPDF\samples\catia5\NIST\ni
st_ctc_02_asme1_ct5210_rc.CATPart" -o "C:\temp\samples output\nist_ctc_02_asme1_ct5210
_rc.pdf" publish "C:\temp\Manifest List\Manifest List.txt"
    
```

The example above will translate the file to each template specified in the referenced manifest list to the given output location, in this case:

C:\temp\samples output\nist_ctc_02_asme1_ct5210_rc.pdf

Note – These PDF files will be created within a single PDF and will be accessible from within attachments.

Publishing without a Template – via the Configuration Manager

It is also possible to publish to no template using the Configuration Manager, both interactively and in the Unified Interface. Running the translation without a template will create a 3DPDF output file with no containing document. To do this, click open the configuration manager then select the **'Write 3D PDF'** tab. From the **'Write Mode'** dropdown, select **'No Template'**.

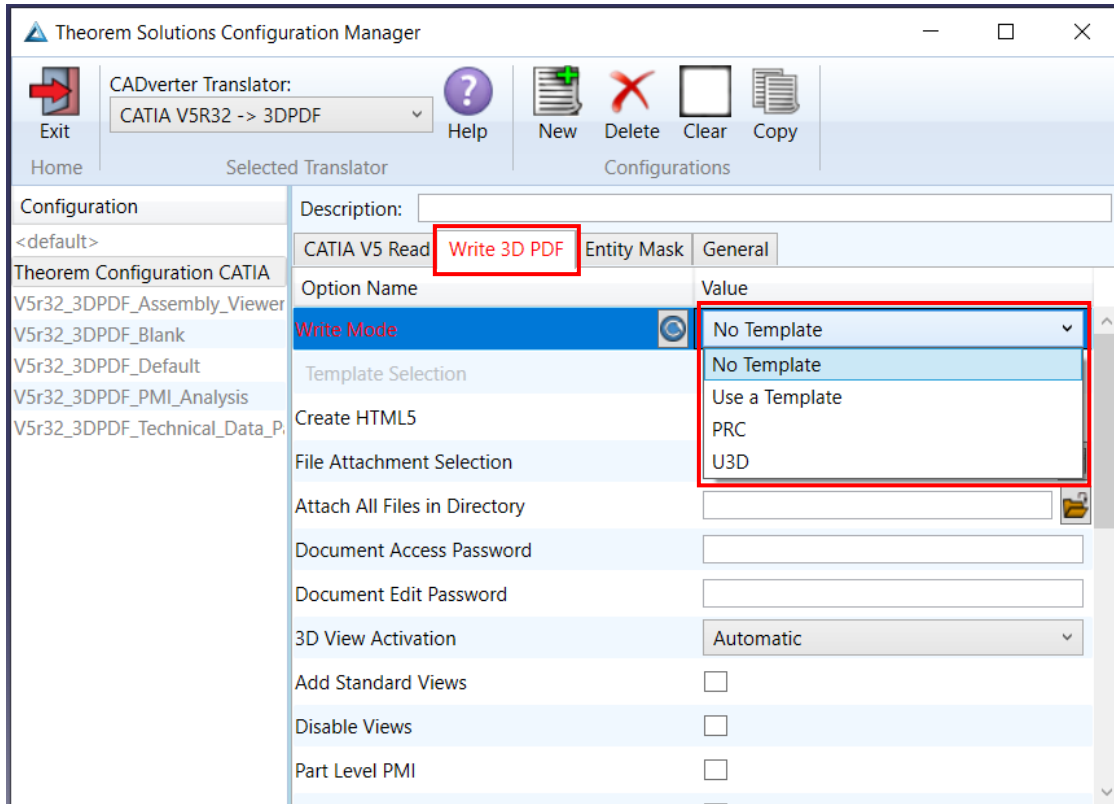

Publishing without a Template – via the Command Line

Publishing without a template can also be achieved via the command line interface.

The format for running a command to publish without a template is as follows (Note! Replace the [XX] seen in the example with the version of CATIA V5 you are using. E.g. for V5 R32, change to CATIA532):

```
<Translator_installation_directory>\bin\cad_run.cmd CATIA5[XX]_3DPDF -i <input_file> -o <output_file>  
publish off
```

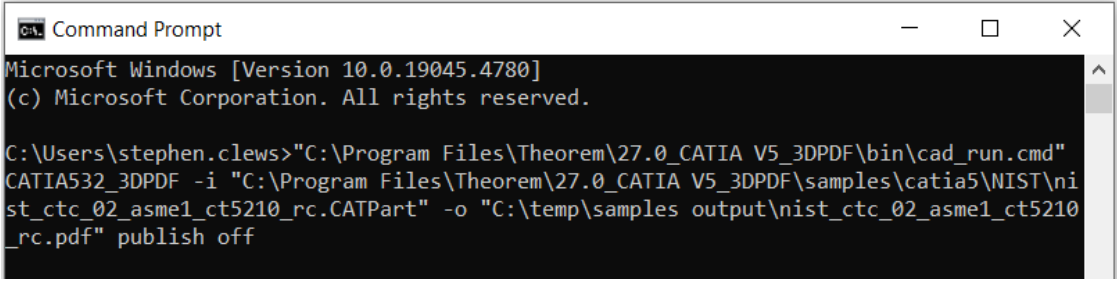

```
Command Prompt
Microsoft Windows [Version 10.0.19045.4780]
(c) Microsoft Corporation. All rights reserved.

C:\Users\stephen.clews>"C:\Program Files\Theorem\27.0_CATIA V5_3DPDF\bin\cad_run.cmd"
CATIA532_3DPDF -i "C:\Program Files\Theorem\27.0_CATIA V5_3DPDF\samples\catia5\NIST\ni
st_ctc_02_asme1_ct5210_rc.CATPart" -o "C:\temp\samples output\nist_ctc_02_asme1_ct5210
_rc.pdf" publish off
```

The example above will translate the file without using a template to the given output location, In this case:

```
C:\temp\samples output\nist_ctc_02_asme1_ct5210_rc.pdf
```

Appendix A – Security Changes to Adobe Reader PDF Documents

Adobe have implemented new security options to disable the auto-play of 3D content in PDF files. The following banner will be displayed upon opening a PDF file that contains 3D content:

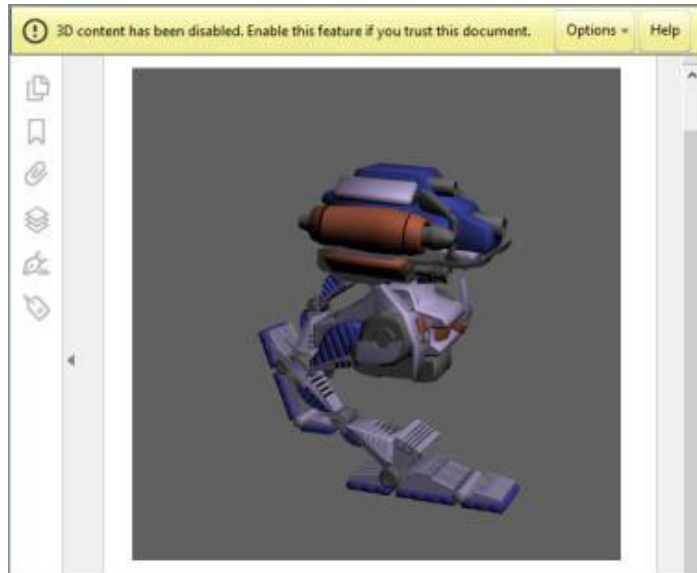

To enable 3D content in the current document:

Click the Options button and then select an appropriate option:

- Trust this document one time only.
- Trust this document always.

To enable 3D content permanently in ALL documents:

- Go to Edit > Preferences > 3D & Multimedia and then select the Enable playing 3D content checkbox.



UK, Europe and Asia Pacific Regions

 THEOREM HOUSE
MARSTON PARK
BONEHILL RD
TAMWORTH
B78 3HU
UNITED KINGDOM

 sales.theorem@techsoft3d.com

 +44 (0) 1827 305 350

USA and the America

 THEOREM SOLUTIONS INC
100 WEST BIG BEAVER
TROY
MICHIGAN
48084
USA

 sales-usa.theorem@techsoft3d.com

 +(513) 576 1100

 THEOREM.COM